

ELEMENT

4



INSTALLATION & USER MANUAL

POWERFAN MKII

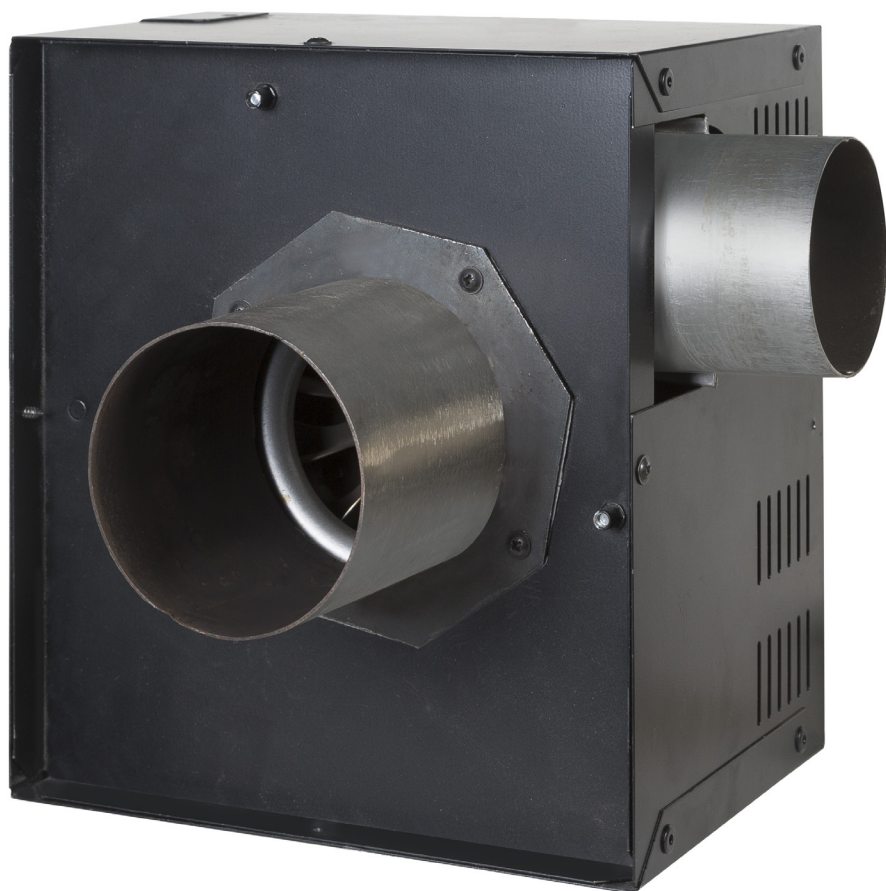

PLEASE LEAVE THIS MANUAL WITH THE FIREPLACE FOR FUTURE REFERANCE

PREFACE

Congratulations on the purchase of your Element 4 PowerFan MKII. The PowerFan is designed to safely discharge flue gases.

The PowerFan makes it possible to use long horizontal stretches and even down-flow configurations.

Read this manual carefully and instruct your customer about the operation and maintenance / inspection of the PowerFan. Leave this manual with the device for future references.

The PowerFan may only be installed by a qualified installer / dealer in accordance with the applicable guidelines at the time of installation.

CE DECLARATION

Hereby we declare that the product released by Element4 meets the essential requirements due to its design and construction.

Product

Flue gas fan

Type

Powerfan MkII

Applicable EC directives and specifications

BSEN 613: 2001 + A1: 2008

ANSI Z21.50 Edition: 2014/02/01 ED: 7; Err. 2015

CSA 2.22 Edition: 2014/02/01

CSA P.4.1: 2015 Ed.3

In connection with the CE inspection, the PowerFan MkII should only be sold as a set and not as individual parts.

This declaration loses its validity when changes to the device are made without written permission of Element4. You can request a copy of the test certificate via info@element4.nl.



Jan Kempers
CEO

CONTENTS

PREFACE	4
CE DECLARATION	4
1 INSTALLATION	7
1.1 Delivery check	7
1.2 Points of attention during installation	7
1.3 Assembly	7
1.4 Flue material	8
1.5 Terminals	9
1.6 Fire safety	10
2 LOCATION OF THERMINALS	11
2.1 Vertical terminal location (C11)	11
2.2 Horizontal terminal location (C31)	11
3 FLUE SYSTEM	12
3.1 Flue configurations	12
3.2 Configurations	13
3.3 Calculating the length of the flue	15
3.4 Extra resistance in the channel	17
3.5 Sample flue configuration calculation	18
3.6 Condensation	20
4 ADJUSTING THE POWERFAN	21
4.1 Set initial position	21
4.2 Start	21
4.3 Fine-tuning	21
5 FUNCTION OF THE REMOTE	22
6 TECHNICAL DATA	22
7 TECHNICAL DRAWINGS	23

1 INSTALLATION

1.1 Delivery check

Note: Check the PowerFan for transport damage before first use and report any damage to your supplier immediately.

Make sure the following parts are included

- PowerFan MkII
- PowerFan module
- PowerFan module connection cables
- 220 volt connection cable
- Adapter / splitter
- 2x Wall terminal Ø100mm
- Installation manual

1.2 Points of attention during installation

Note: The PowerFan must be accessible at all times for service and inspection. It should be mentioned here that the regular service hatch of Element 4 (BDLE4) is not sufficient for the size of the PowerFan MkII. The installer must make a provision for this himself. *Figure 1.1.*

The powerfan should be placed in a well ventilated area. It should be separated from the fireplace. Placing it in a completely separate room is preferred.

It is recommended that the PowerFan MkII be placed in a room that is large enough for the PowerFan to be removed without having to interrupt the conversion.

Avoid extreme, wind-sensitive positions for the flue gas outlet, since this can lead to annoying shutdowns of the system (See also **CHAPTER 2**).

NB: A minimum distance of two meters from the fireplace is required to prevent the fan from malfunctioning.

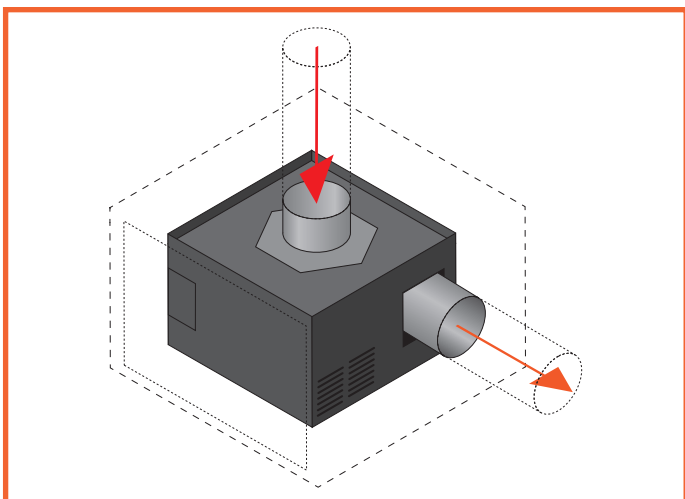

Figure 1.1 - Service area around the PowerFan MkII

The PowerFan does not require any additional maintenance, but an annual inspection is recommended. Provide the installation with removable connections on the PowerFan. This facilitates the disassembly of the motor or circuit board.

1.3 Assembly

The PowerFan has three mounting brackets. For the PowerFan to function properly, it makes no difference how the outlet is positioned (*Figure 1.2*).

Make sure the PowerFan brackets are not tightened too tightly to prevent resonance of the casing, for unnecessary noise.

Note: Preferably use rubber vibration dampers (not supplied by Element4) between the PowerFan and the wall to prevent resonance.

The inside of the fan is equipped with rubber suspension for more flexibility.

1.3.1 Mounting PowerFan Module

The module ensures that communication can occur between the fireplace and PowerFan. The cable required for this is supplied with the PowerFan. See *Figure 1.3*.

When the PowerFan is not connected to the receiver of the fireplace, it will function as a regular fan when connected to the socket. It is therefore important to check that the PowerFan is correctly connected. When the fire is off, the fan must also be off.

1.3.2 Assembly flue material

Ensure that all connections of the individual flue parts are closed. Leakage will adversely affect the operation of the PowerFan and cause the fire to switch off.

Note: Element4 cannot be held liable for leaks of flue poured into concrete or buried flue

1.3.3 Power connection

The PowerFan is equipped with a service plug. For the power supply, a 230VAC - 50Hz wall socket must be mounted within a range of 1 meter from the PowerFan.

1.3.4 PowerFan cable

The cable must not come into contact with the flue material. The standard length is 20 meters, this can be replaced by a longer cable.

1.4 Flue material

The PowerFan can be connected with the following brands of flue gas pipes.

Concentric

- OnTop / Metaloterm (eg the SU line)
- Jeremias
- Poujoulat
- Other flue material that has been tested according to the applicable standards.

Single walled

- Flexible tube
- Rigid tube, such as
 - Ontop Metaloterm (eg the ME line)
 - Jeremias
 - Poujoulat

Ensure that the used flue materials meet the requirements for the conditions of use specified in this manual. The performance declaration provides more information on this (see **Table 1.1**).

EN1856-1 T600 N1 D Vm L50040 G0

EN1856-1	=	Norm number
T600	=	Temperature class
N1	=	Pressure density N = Under pressure P = Over pressure H = High over pressure
D	=	Condensation resistance D = Dry W = Wet
Vm L50040	=	Corrosion class + material types Thickness of the inner flue
G0	=	Chimney fire resistancy (G = Yes, 0 = No) Distance to flammable material (in mm)

Table 1.1

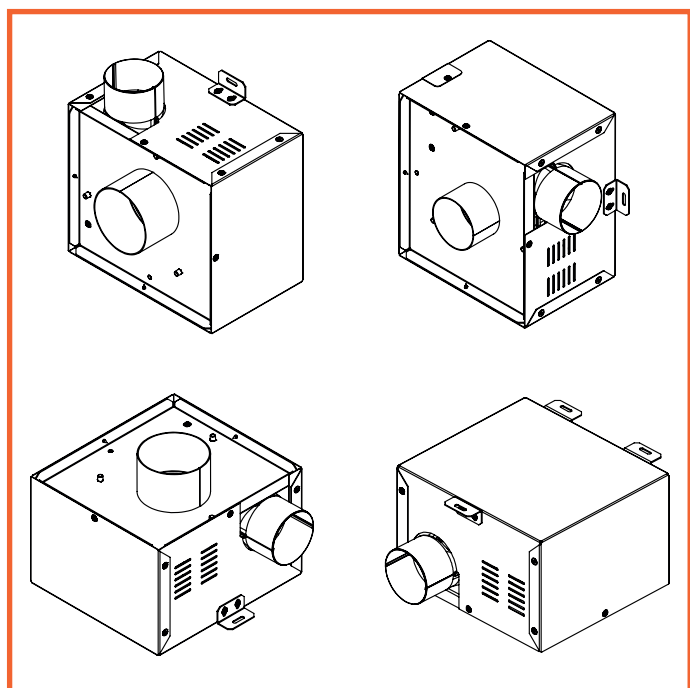

Figure 1.2 - Mounting possibilities PF MkII

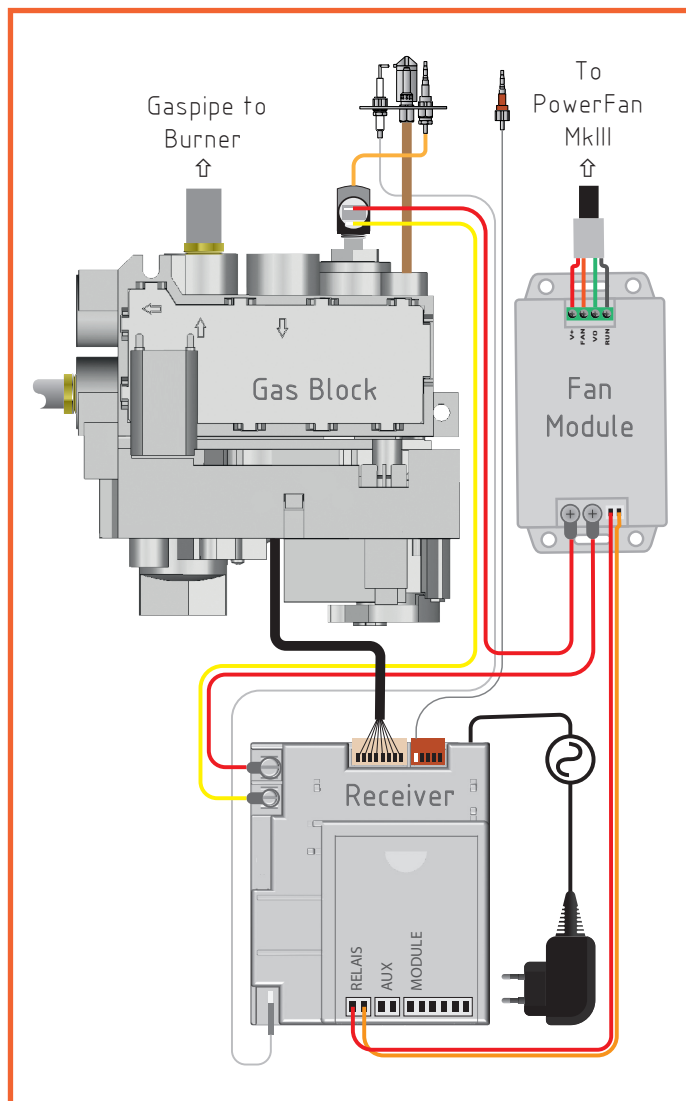

Figure 1.3 - Connection scheme PowerFan MkII

1.5 Terminals

For the proper functioning of your PowerFan, the supply of air and the discharge of combustion gases must not be impeded. You can end up both horizontally (by means of a wall terminal) and vertically (by means of a roof terminal).

Note: Due to the mechanical discharge of the flue gases, it is not necessary for the combustion air supply and the flue gas discharge to end up in the same pressure range.

Two identical horizontal outlets are supplied as standard. The outlet position must at all times comply with local regulations regarding nuisance and ventilation openings. For other outlets, these regulations must also be taken into account.

1.5.1 Distance between outlets

When opening into the same horizontal outlet area, the following distances must be observed, with regard to the outlets of supply air and flue gas discharge (see also figures 1.4 and 1.5);

D_h = Horizontal distance = at least 30 cm
 D_v = Vertical distance = minimum 15 cm, whereby a partition must be used to prevent mixing of combustion air (blue arrow) and flue gases (red arrow).

In the case of a vertical outlet, both for supply ($\varnothing 100$) and discharge ($\varnothing 80$) one must create a feed-through with approved regular flueage materials, as shown in figures 1.6 and 1.7.

1.5.2 Supply of combustion air

The supply of combustion air may only come from outside. You must take into account a thermal bridge. The combustion air supply may be carried out in PVC.

Pay attention:

Never terminate flue gasses under the fresh air supply, when both terminals are on the same wall.

Make sure that both outlets are at least 30 centimeters from the ground level and that there is no way to block the openings.

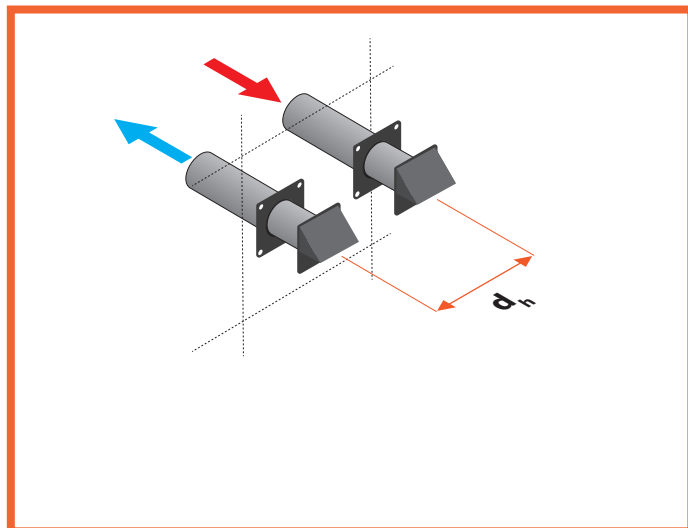

Figure 1.4 - Verticale afstand tussen uitmondingen

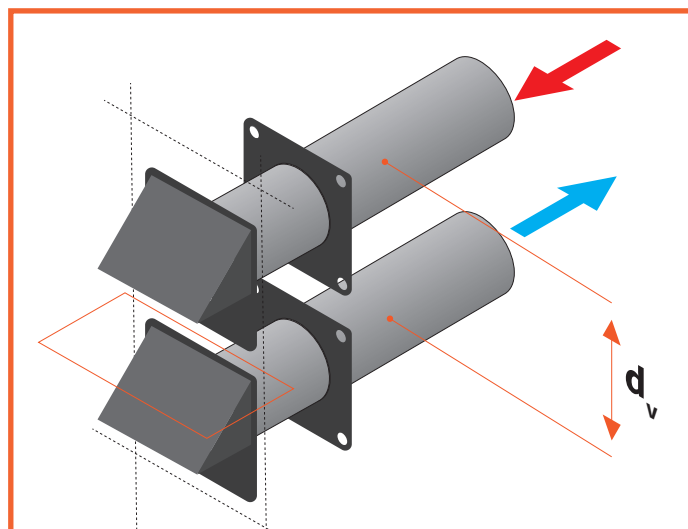

Figure 1.5 - Horizontal distance between terminals

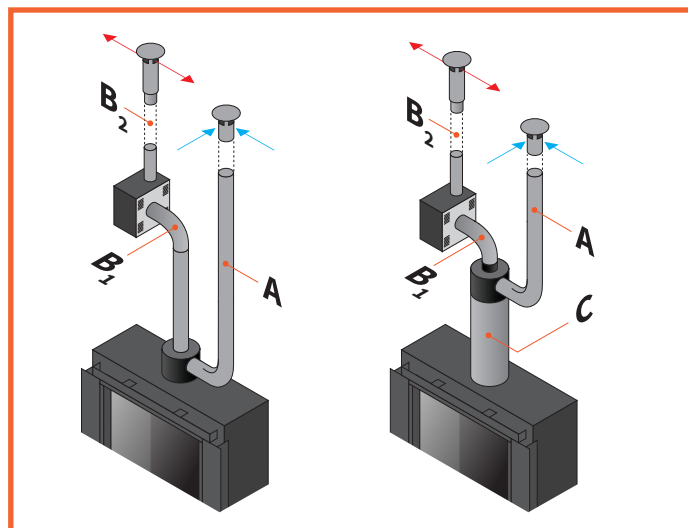

Figure 1.6 - Vertical terminals

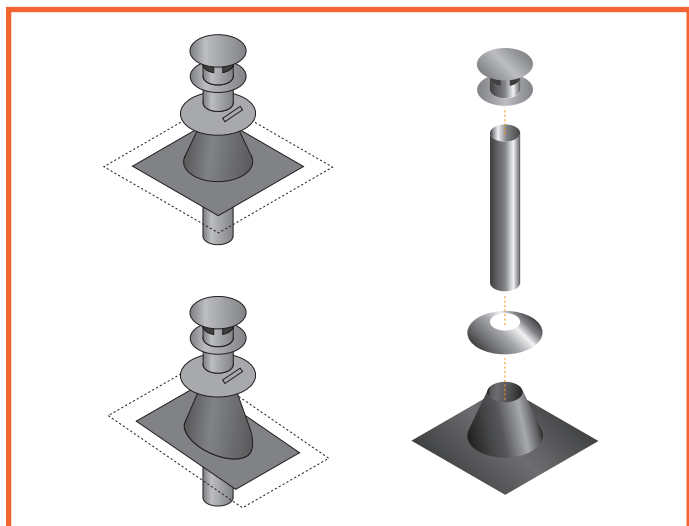

Figure 1.7 - Roof terminal supplies

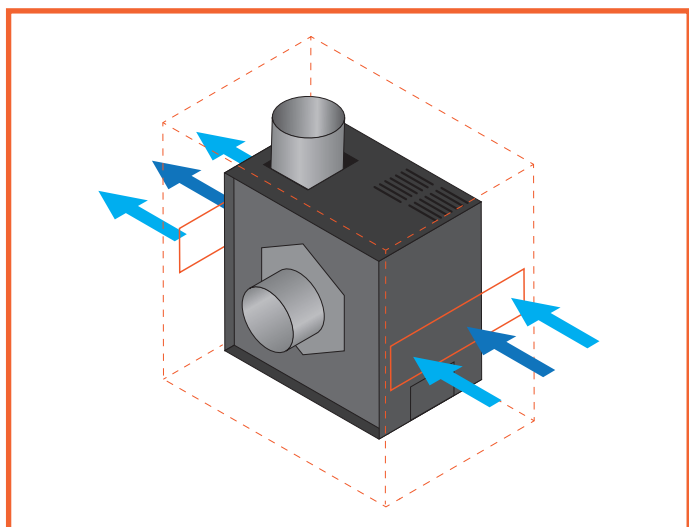

Figure 1.8 - Ventilation around PowerFan MkII

1.6 Fire safety

To ensure fire safe installation make sure the PowerFan is placed at least 3 meters away from the fireplace.

1.6.1 Installation of the PowerFan

Always provide a free space around the PowerFan with a minimum of 100mm. Take extra account of distance with regard to combustible materials and ventilation. When the PowerFan is placed in an enclosure, the necessary ventilation openings must be made in the enclosure (See **Figure 1.8**).

Note: Provide the enclosure with at least 2 gratings with a free passage of 100mm² per grid.

1.6.2 Flue material

Single-walled flue material must always be covered with non-combustible building materials. In all other cases, concentric flue material must always be used. Concentric flue material can also be used, whereby the outer casing serves as an insulation and ventilation option for the inner pipe.

Note: Please make sure that no heat bridges can occur by brackets around the concentric or single-tube material.

2 LOCATION OF THERMINALS

2.1 Vertical terminal location (C11)

Distance	Terminal 1,2 of 3	
On the same roof level	> 6m	*
On a different roof level	> 3m	* & **
On a lower placed wall	> 2m	*
On a higher slanted surface	> 6m	***

"Distance" = minimum distance required to position the outlet to prevent adverse effects with regard to;

A ventilation opening of a used room, toilet or bathroom
 Supply of heated air, when the supply flows through a used room.
 A window that can be opened and is located near a used room, toilet or bathroom

NB: These dimensions may differ from your local regulations! Always check local laws and regulations before making an installation

- * If the required distance is not feasible, the rules regarding the outlet position take precedence.
- ** If the outlet is placed at least one meter higher than the inlet opening, or a window that can be opened.
- *** If the required distance is not feasible, the outlet must be placed at least one meter above the highest façade / roof.
- (4) In addition, the end may not be placed closer than 300 mm to an opening in the building that is provided for placing a built-in element such as a window frame.

2.2 Horizontal terminal location (C31)

	Terminal position	mm
A ⁽⁴⁾	Directly below an opening, ventilation stone, casement window etc.	600
B	Above an opening, ventilation stone, casement window etc.	300
C	In addition to an opening, ventilation stone, casement window etc.	400
D	Under gutters or drain pipes	300
E	Under eaves	300
F	Under balconies or roofs of open garages	600
G	From a vertical drain pipe	300
H	From an inside or outside corner	600
I	Above ground roof or balcony level	300
J	From a surface opposite the tip	600
K	From an end opposite the tip	600
L	From an opening in the open garage (eg door, window in the house)	1200
M	Vertically from one end to the same wall	1500
N	Horizontally from one end to the same wall	300
P	From a vertical structure on the roof	600
Q	Above the intersection with the roof	150

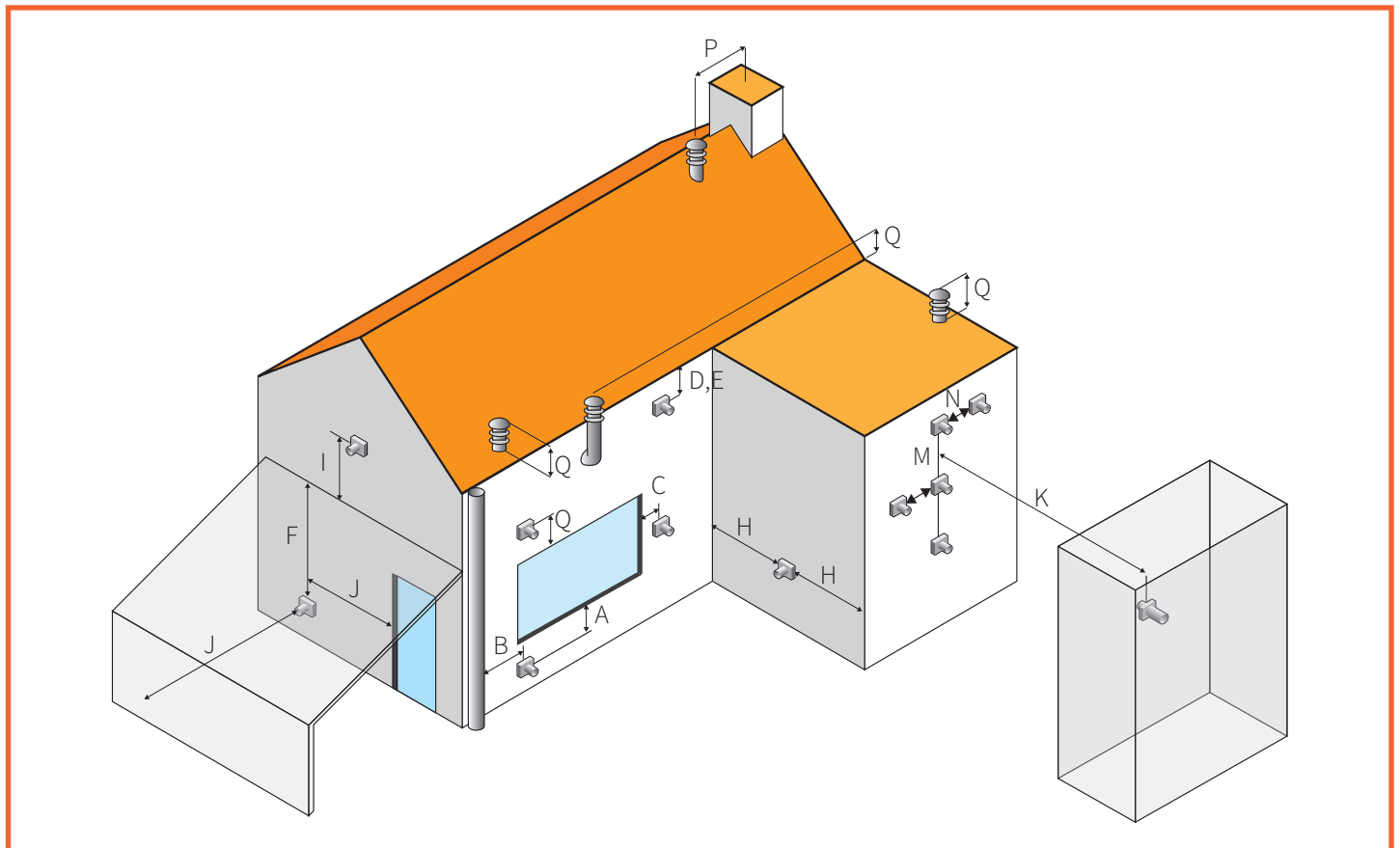

Figure 2.1 - Wall terminal location

3 FLUE SYSTEM

3.1 Flue configurations

The PowerFan MkII is a very flexible solution for difficult flue situations for all Element4 fireplaces. By making use of a separate air supply and flue gas discharge, you can achieve the desired flue situation in many ways.

In this chapter these different options are explained, in what ways the flue situation can be carried out.

The following applies to all construction options in **chapter 3.2** (see also accompanying **figures 3.2 to 3.8**):

- **A** = Combustion air supply channel
Pipe diameter A is $\varnothing 100$ mm
- **B₁** = Flue gas outlet
Pipe diameter **B₁** is $\varnothing 100$ mm
- **B₂** = Flue gas outlet
Pipe diameter B2 is $\varnothing 80$ mm
- **C** = Concentric channel
Diameter is $\varnothing 200/130$ mm or $\varnothing 150/100$ mm

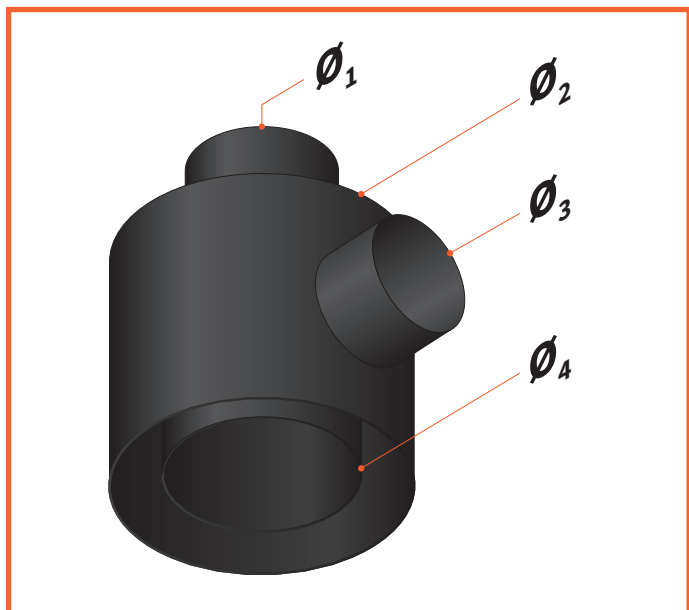

Figure 3.1 - Adapter 200/130

	Adapter 200/130
\varnothing_1	$\varnothing 100$ mm
\varnothing_2	$\varnothing 200$ mm
\varnothing_3	$\varnothing 100$ mm
\varnothing_4	$\varnothing 130$ mm

Table 3.1 - Measurements adapter

Note: In the event that a PowerFan MkII is applied to a fireplace with a $\varnothing 150/100$ flue connection, the flue must be increased to $\varnothing 200/130$ on the supplied adapter / splitter or a separate $150/100$ concentric splitter must be used. The latter component is not provided by Element4. (**Image 3.1** and **table 3.1**)

- (1) = Terminal area 1
- (2) = Terminal area 2

Chapter 3.3 explains how the above-mentioned lengths can be calculated for each construction situation.

Because not every flue configuration is completely straight, bends must often be used. When the PowerFan MkII is used, the flue configuration is often a special case. **Chapter 3.4** explains the effect of the bends and also of a negative flue on the length of your flue configuration.

In **chapter 3.5** you will find a calculation method for calculating the flue configuration. Where necessary, you can always consult the manufacturer in exceptional situations.

3.2 Configurations

With the PowerFan MkII, the discharge of the fireplace can be constructed in two ways, respectively directly with separate supply and discharge and with a (partially) concentric structure.

Below a more detailed explanation of the different mounting systems.

3.2.1 Configuration 1

Separate air supply and flue gas discharge directly on the fireplace.

Supply and discharge are split directly on the fireplace by means of the included splitter. The combustion air and flue gases can be individually guided with a rigid or flexible tube to the desired terminal area. This can be the same area for both terminals, but both can also end into a different area. See also **figures 3.2** to **3.4** for various variations of this mounting system.

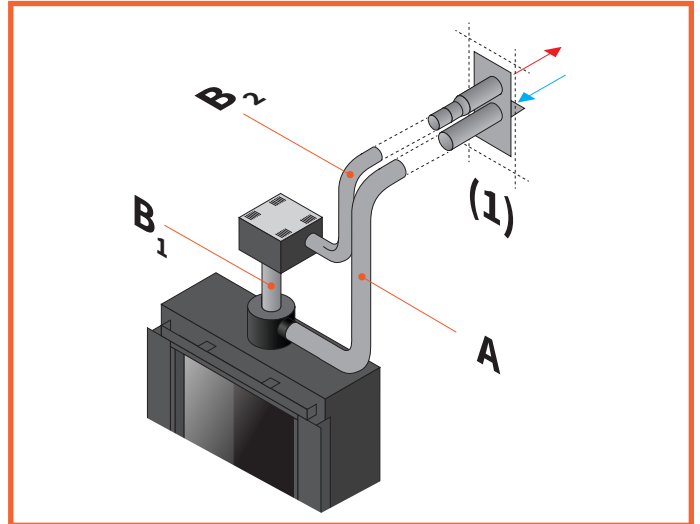

Figure 3.2 - Adapter directly on the fireplace and with horizontal terminal in the same area

Components

In system 1 we recognize the following components

A = Supply of combustion air

B = Flue gas discharge, where **B₁** is the part before the PowerFan and **B₂** is the part after.

(1) = Terminal area 1

(2) = Terminal area 2

3.2.2 Configuration 2

(partial) concentric flue configuration.

In this situation the flue (partially) is carried out with a regular concentric tube, after which the flue is split by means of the included adapter. The combustion air and flue gases can be led individually with a rigid or flexible tube to the desired terminal area. This can be the same discharge area for both terminals, but both can also lead to a different area. See **figures 3.5** to **3.9** for different variations of this construction system.

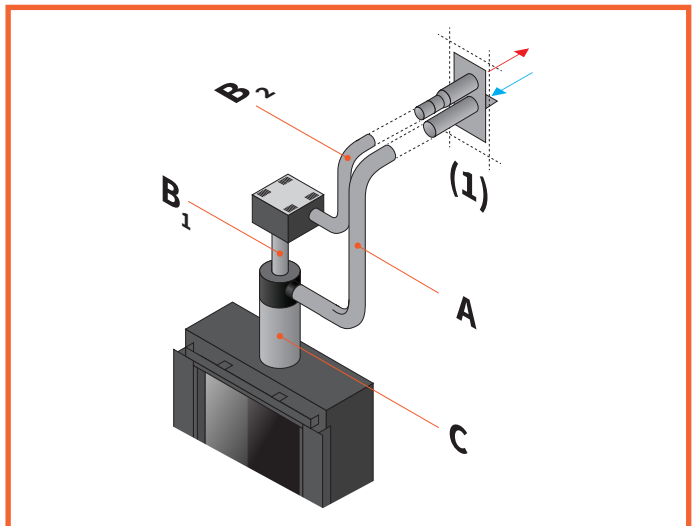

Figure 3.5 - (Partial) concentric flue configuration with horizontal terminal in the same area

Components

In system 2 we recognize the following components

A = Supply of combustion air

B = Flue gas discharge, where **B₁** is the part before the PowerFan and **B₂** is the part after.

C = Concentric tube Ø200 / 130 (or Ø150 / 100)

(1) = Terminal area 1

(2) = Terminal area 2

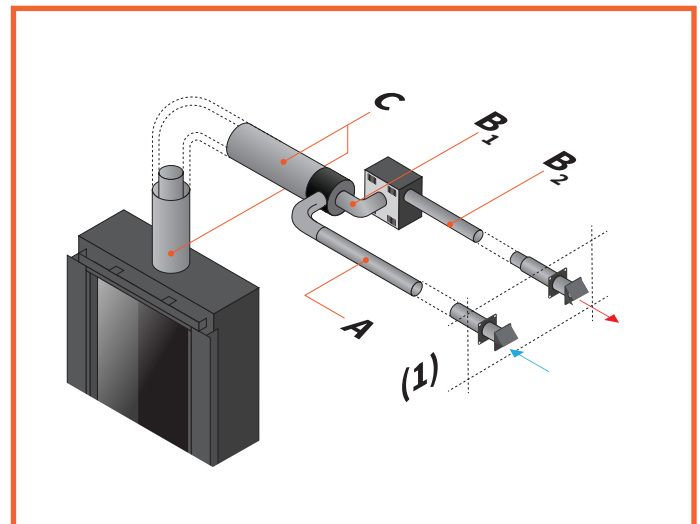

Figure 3.8 - (Partial) concentric flue configuration with horizontal terminal in the same area (II)

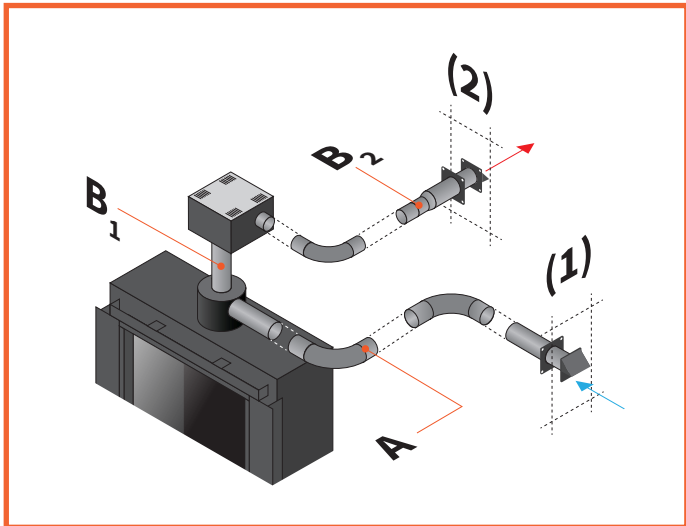

Figure 3.3 - Adapter directly on the fireplace and with horizontal terminal in a different area

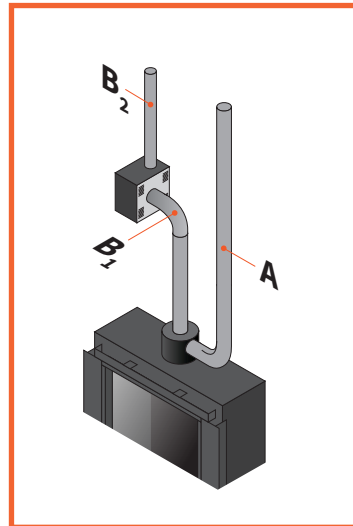

Figure 3.4 - Roof terminal with direct split by adapter

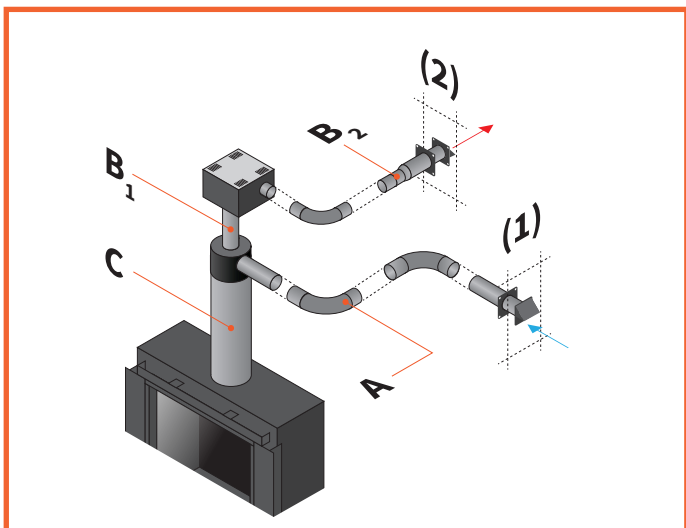

Figure 3.6 - (Partial) concentric flue configuration with horizontal terminal in a different area

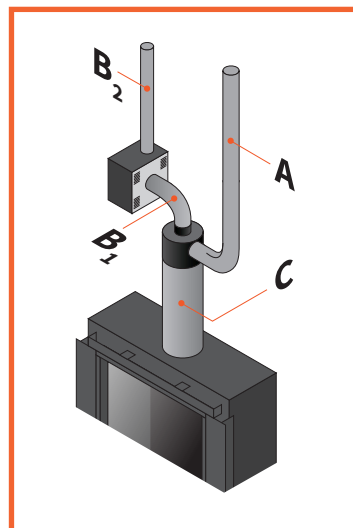

Figure 3.7 - Roof terminal with (partial) concentric flue

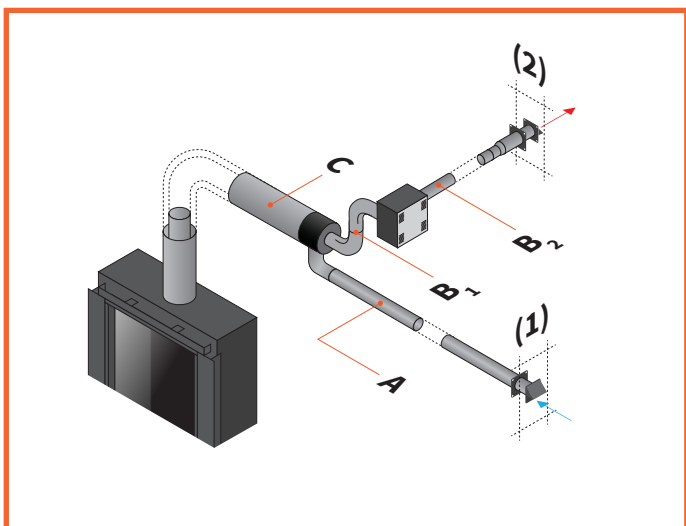

Figure 3.9 - (Partial) concentric flue configuration with horizontal terminal in a different area (II)

3.3 Calculating the length of the flue

3.3.1 Flue construction - type 1

Immediate split supply and removal (See *figure 3.10*)

Maximum discharge lengths for the
When air supply and flue gas discharge are split directly on the fireplace, the total length of both may cover 40 meters with the following requirements per part:

L = max. 20 m

D = min. 2.0 m

And

(1) = Terminal

3.3.2 Flue construction - type 2

(Partly) Concentric tube

When working with a concentric tube before the supply and discharge are split, the total length of supply and discharge can be 30 meters. In *figure 3.11* to *3.13*. You will see three options that fall under type 2.

Each option is explained further below

Flue lengths for construction - type 2.1

Maximum length of the concentric tube $\varnothing 200 / 130$ (*Figure 3.11*)

In this situation, the flue situation is carried out almost completely concentrically, with the supply and discharge being split just before the outlet. *Figure 3.11* serves as a reference for the minimum and maximum lengths for this construction situation, where

K = max. 30 meters

And

(1) = Terminal

Also in this situation it holds that the length of the flue before the PowerFan must be at least 2 meters i.v.m. possible damage.

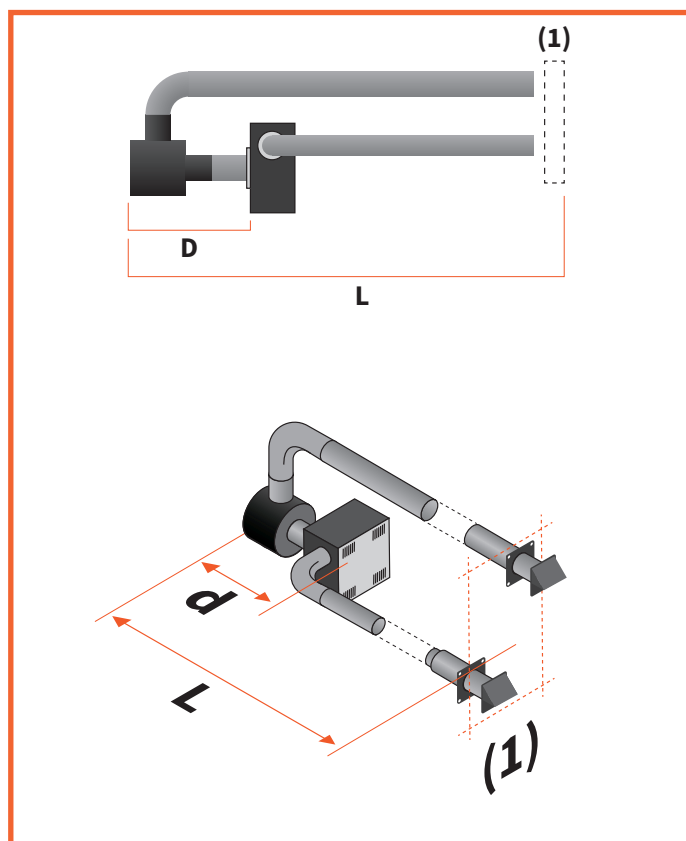

Figure 3.10- Flue construction - type 1

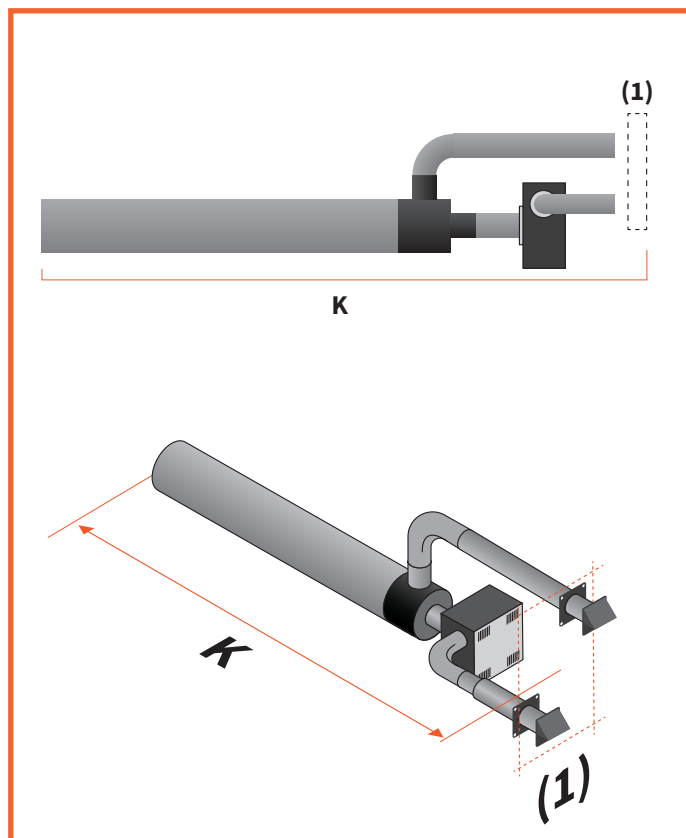

Figure 3.11 - Flue construction - type 2.1

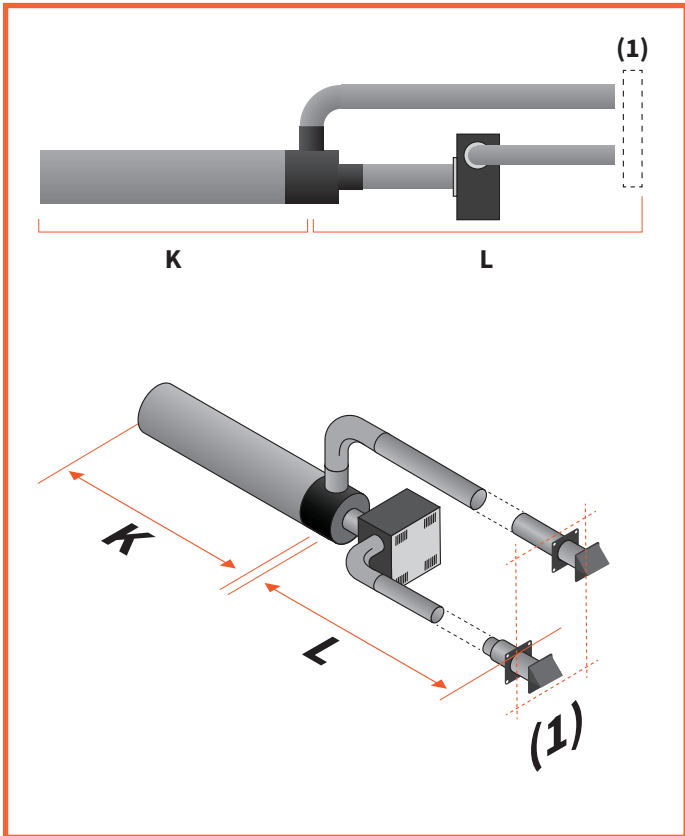

Figure 3.12 - Flue construction - type 2.2

Flue lengths construction - type 2.2

Partial concentric flue - size Ø200 / 130 (See *figure 3.12*)

In this situation, a part of the flue is executed concentrically, after which the supply and discharge are split and end up separately. Figure 3.12 serves as a reference for the minimum and maximum lengths for this construction situation, where

K + L = Total flue length at which

K = max. 30 meters

L = $20 - \frac{2}{3} * K$ meters

And

(1) = Terminal

Method

First calculate the length of the concentric part of the flue. Don't forget to include the extra resistance of bends and any negative flue lengths. Then read in table 3.2 the maximum length of your split supply and discharge.

Flue lengths construction - type 2.3

(Partial) Concentric flue - flue size Ø150 / 100 (See *Figure 3.13*)

In this situation, (a part of) the flue is executed concentrically in Ø150 / 100, after which the supply and discharge are split and end up separately.

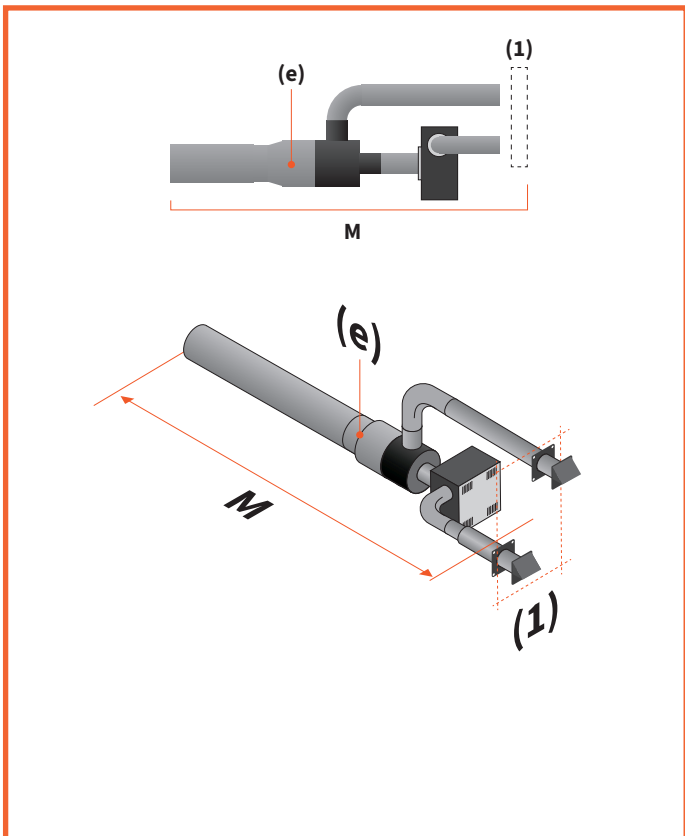

Figure 3.13 - Flue construction - type 2.3

Note: This flueage situation should be seen as if the fireplace is being split directly.

If the Ø150 / 100 flue is used, it must be enlarged before it can be connected to the adapter.

Figure 3.13 serves as a reference for the maximum lengths for this construction situation, where;

M = max. 20 m

And

(e) = Enlarger

(1) = Transit

Also in this situation it holds that the length of the flue before the PowerFan must be at least 2 meters i.v.m. possible damage.

3.4 Reduce split drain to concentric channel

Maximum discharge lengths - Type 3

In this situation, a part of the flue channel is executed concentrically, after which the supply and discharge are split, but unlike the previous situations, are brought back again into a concentric channel. **Figure 3.12.** serves as a reference for the minimum and maximum lengths for this construction situation, where;

$$K_1 + L + K_2 = \text{Total discharge length}$$

where

$$K_{\text{total}} = \text{max. 30 meters}$$

$$L = 20 - 2/3 * K \text{ meters}$$

And

(1) = Terminal

Method

First calculate the length of the first concentric part of the outlet (K_1). Then do the same for (the longest of) the split input and output (L) and finally calculate the length of the concentric part after combining the split input and output (K_2). Do not forget to include the extra resistance of bends and any negative discharge lengths.

Add both **K**-sections together and fill in the answer in the above formula or read from the table whether the desired length **L** is allowed in this configuration.

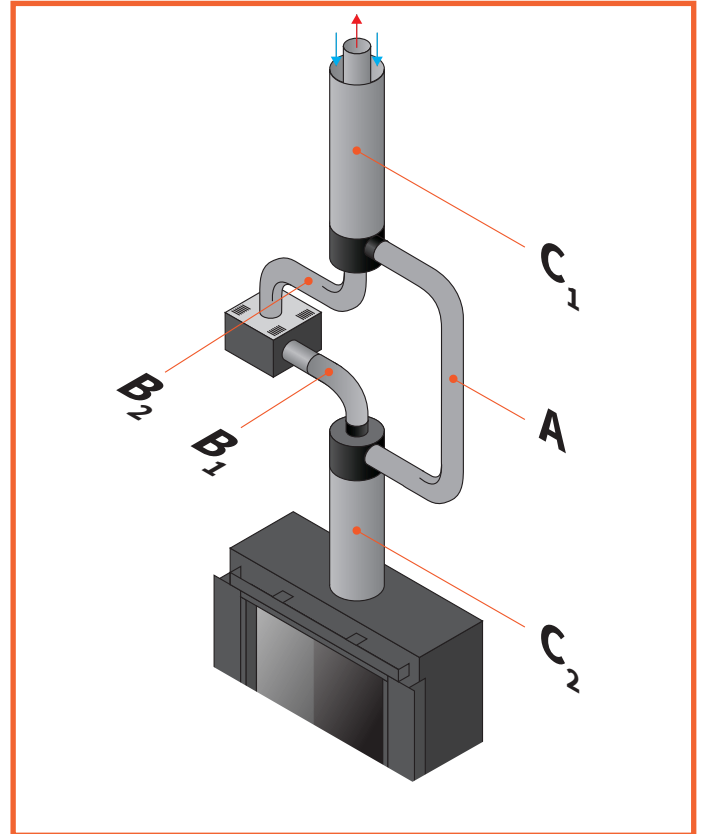

Figure 3.14 - System type 3 - Vertical terminal

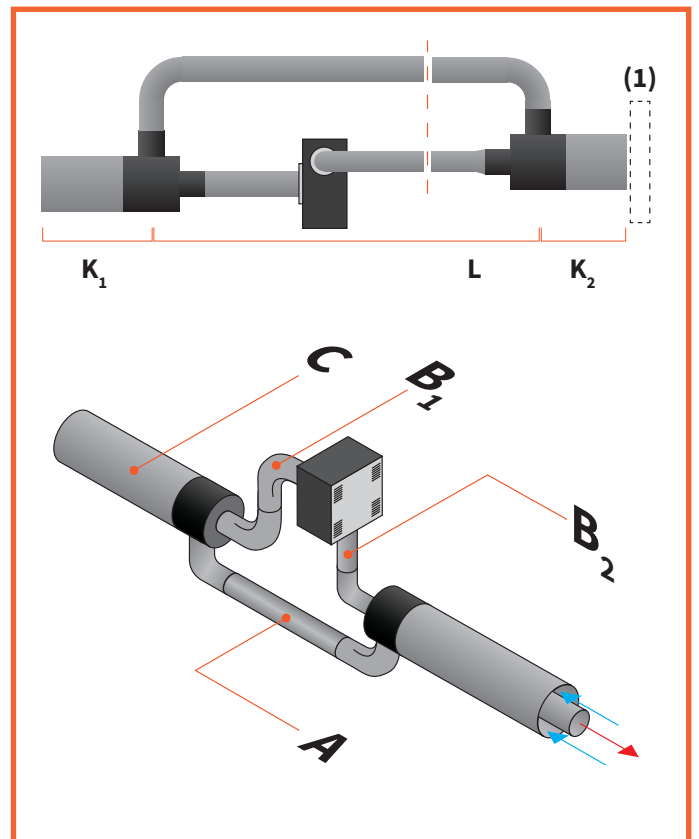

Figure 3.15 - System 3 - Horizontal terminal

3.5 Extra resistance in the channel

As with a regular, non-mechanical flue situation, adding bends in the flue configuration of the PowerFan also provides extra resistance. These bends must be taken into account by counting them as an extra flue length.

There are two types of bends that may occur in a flue situation.

- **N**-bends
Curves from the vertical plane to the horizontal plane or
Curves from the horizontal to the vertical.
- **Q**-bends
Curves in the horizontal plane

With these two bends, there are three situations that can offer extra resistance to your flue (*Figure 3.14*).

- **Q**-bends (both **90°** and **45°**) are calculated as a 0.5 meter discharge length.
- Positive **N**-bends (both **90°** and **45°**) are calculated as a 0.25 meter discharge length.

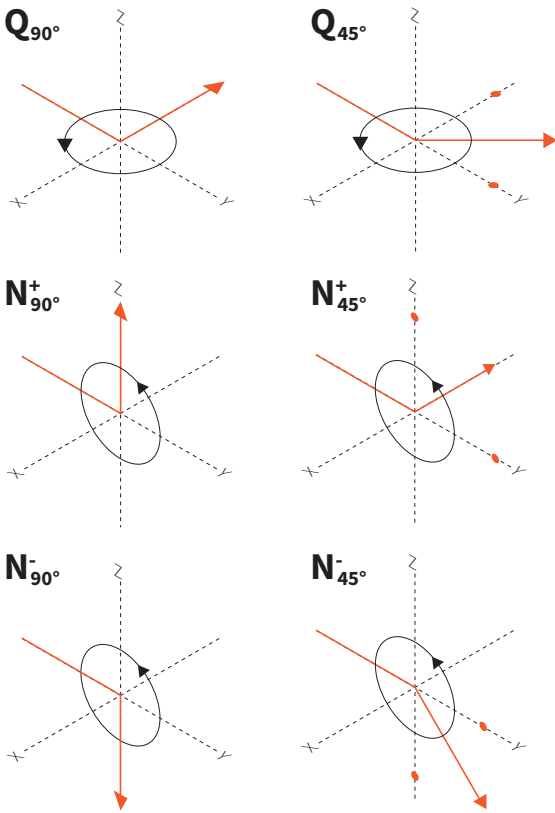

Figure 3.14 - Bend directions for extra resistance calculation

After a negative **N**-bend, that is, an **N**-bend after which the flue goes down vertically (**N**), the entire discharge length must be counted twice until it bends again to the horizontal plane or rises again. (*Figure 3.15*).

So for **C₂**, every meter counts for 2 meters.

The calculated extra resistance of the bends applies to all superstructure systems.

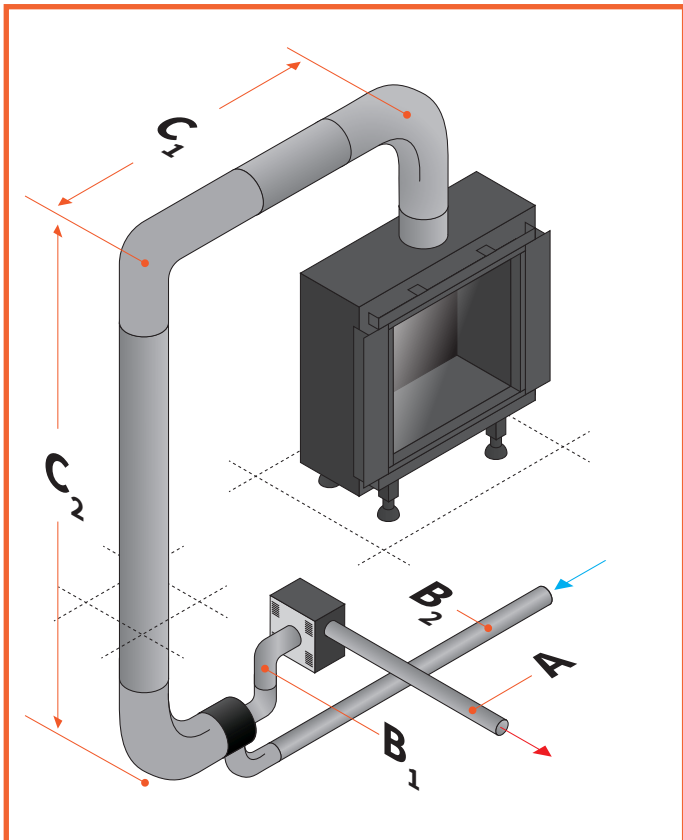

Figure 3.15 - Example setup of negative vertical flue

3.6 Sample flue configuration calculation

Step 1

Consider which flue configuration is required

Step 2

Calculate the length of the desired concentric part (**C**) of your configuration.

Note: Do not forget to include the bends and negative flue in your calculation.

Step 3 - option a

Then calculate the desired lengths from supply to the adapter (**A**) and discharge from the adapter (**B₁**) and (**B₂**). For your convenience, always choose the longest of both. So you only have to calculate the length once.

Enter the formula "**L** = 20 - 2/3 * **K**" to see how long your supply and removal can be.

- **K** is the length of your concentric part.
- **L** is the maximum length of the supply and discharge

Step 3 - option b

Check whether the discharge lengths for the supply to - and the discharge from the adapter are permitted with the desired concentric length, by reading in **table 3.2** the maximum length of the remaining air supply / flue gas discharge (**L**) corresponding to the desired concentric length (**K**).

If **L** is less than or equal to the desired length, you can install your flue configuration without any problems.

Step 4

Add **K** and **L** to determine the full length of your flue.

For **K** and **L** together, this distance may never be longer than 30 meters and the Powerfan should be always minimum of two meters away from the fireplace (distance **B₁**).

K	L	K	L	K	L
0 m	20 m	10,5 m	13 m	20,5 m	6,25 m
1 m	19,25 m	11 m	12,5 m	21 m	6 m
1,5 m	19 m	11,5 m	12,25 m	21,5 m	5,5 m
2 m	18,5 m	12 m	12 m	22 m	5,25 m
2,5 m	18,25 m	12,5 m	11,5 m	22,5 m	5 m
3 m	18 m	13 m	11,25 m	23 m	4,5 m
3,5 m	17,5 m	13,5 m	11 m	23,5 m	4,25 m
4 m	17,25 m	14 m	10,5 m	24 m	4 m
4,5 m	17 m	14,5 m	10,25 m	24,5 m	3,5 m
5 m	16,5 m	15 m	10 m	25 m	3,25 m
5,5 m	16,25 m	15,5 m	9,5 m	25,5 m	3 m
6 m	16 m	16 m	9,25 m	26 m	2,5 m
6,5 m	15,5 m	16,5 m	9 m	26,5 m	2,25 m
7 m	15,25 m	17 m	8,5 m	27 m	2 m
7,5 m	15 m	17,5 m	8,25 m	27,5 m	1,5 m
8 m	14,5 m	18 m	8 m	28 m	1,25 m
8,5 m	14,25 m	18,5 m	7,5 m	28,5 m	1 m
9 m	14 m	19 m	7,25 m	29 m	0,5 m
9,5 m	13,5 m	19,5 m	7 m	29,5 m	0,25 m
10 m	13,25 m	20 m	6,5 m	30 m	0 m

Table 3.2 - Permitted lengths for air supply and flue gas discharge L at concentric stretch K

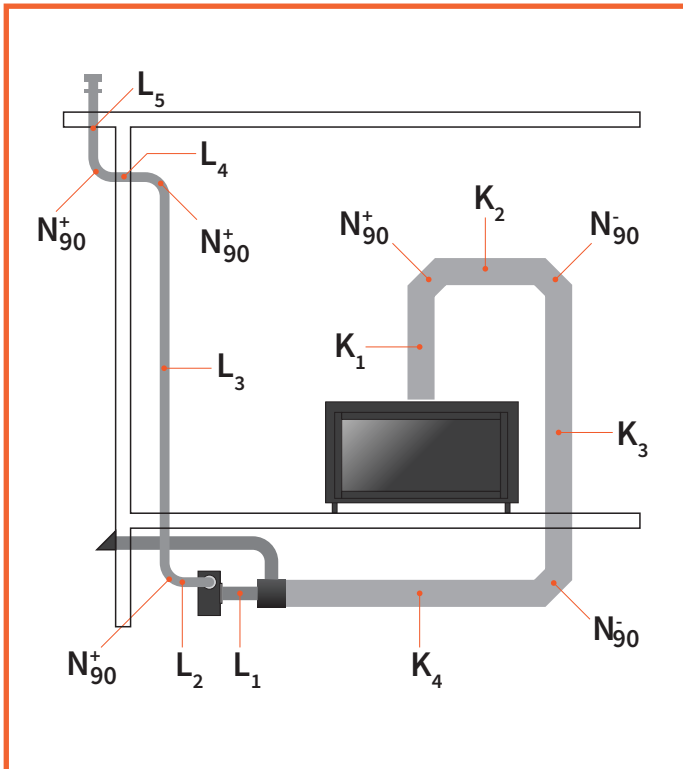

Figure 3.16 - Example set-up negative flue

K_1	1m	L_1	0,25m	N^+	0,25m
K_2	1m	L_2	0,25m	N^-	-
K_3	4m	L_3	6m		
K_4	4m	L_4	0,5m		
		L_5	0,5m		

Table 3.3 - Values for Figure 3.16

3.6.1 Example

Step 1

See the desired setup in **Figure 3.16** and **Table 3.3**. The first part of the flue is designed concentrically, after which the supply and flue are split. The supply is discharged directly via a wall outlet. The flue must open vertically through a roof.

Step 2

- Add all **K** stretches for the total concentric part.
- Count **K₃** double because it goes down.
- Don't forget to add the two positive **N⁺** turns. You may neglect the negative turns **N⁻**; these are already included in the negative vertical stretch.

- $K_1 + K_2 + 2 * K_3 + K_4 + 2 * N^+$

So

$$1m + 1m + 2 * 4m + 4m + 2 * 0.25m = 15m$$

Step 3

Now you know the length of the concentric part. Enter this in the formula " $L = 20 - 2/3 * K$ "

$$L = 20 - 2/3 * 15 = 10 \text{ m}$$

Or

read **L** from **table 3.2** at "**K** = 15m".

For **K** = 15 m, the value **L** = 10 m is also shown in the table

Because the flue outlet is longer than the air supply, calculated from the adapter, we check whether this length meets the maximum permitted length.

- $L_1 + L_2 + L_3 + L_4 + L_5 + 2 * N^+$

So

$$0.25m + 0.25m + 6m + 0.5m + 0.5m + 2 * 0.25m = 8m$$

The desired length of 8 meters is less than the maximum permitted length of 10 meters, so this setup was approved.

Step 4

Add **K** and **L** together to check that the full length of the flue is no more than 30 meters.

- $15 + 8 = 22m$, so that's good.

Also check if the PowerFan is at least 2 meters away from the fireplace. This is also the case, so you can install the PowerFan without problems.

3.7 Condensation

If the entire flue configuration is more than 15 meters or if it is expected that condensation will otherwise occur in the flue, e.g. when a large horizontal flue stretch is present (**H_z** in **figure 3.17**) a condensate flue must be installed in the system, as supplied by the companies mentioned in **chapter 1.4**.

In these cases always ensure a (minimum) 3° course, approximately 50 mm per linear meter, on the horizontal parts of the flue, so that the water can flow away at any time.

The condensate can be collected in, for example, a siphon cup or a condensate collector (T-shaped) with tap, as shown in **figures 3.16** and **3.17**, parts **(1)** and **(2)** respectively. Place the traps / catcher at every lowest point in the flue and before the outlet of the PowerFan. Under no circumstances should the PowerFan be the lowest point of the flue situation, to prevent problems and damage to the fan.

Note: The siphon cup getting dry can cause flue gases to escape. To stop this from happening, there are liquid-free traps.

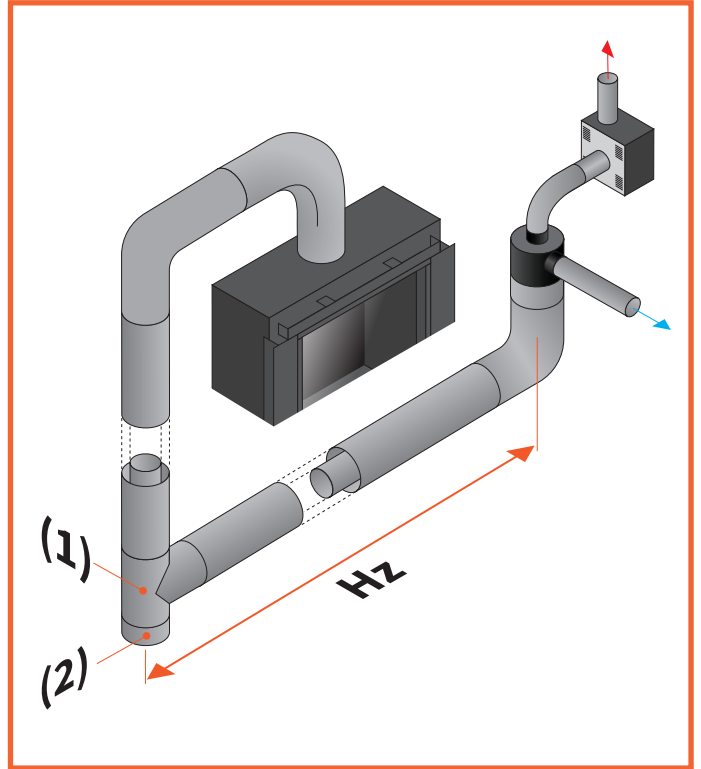

Figure 3.17 - Example of condensation tap for H_z

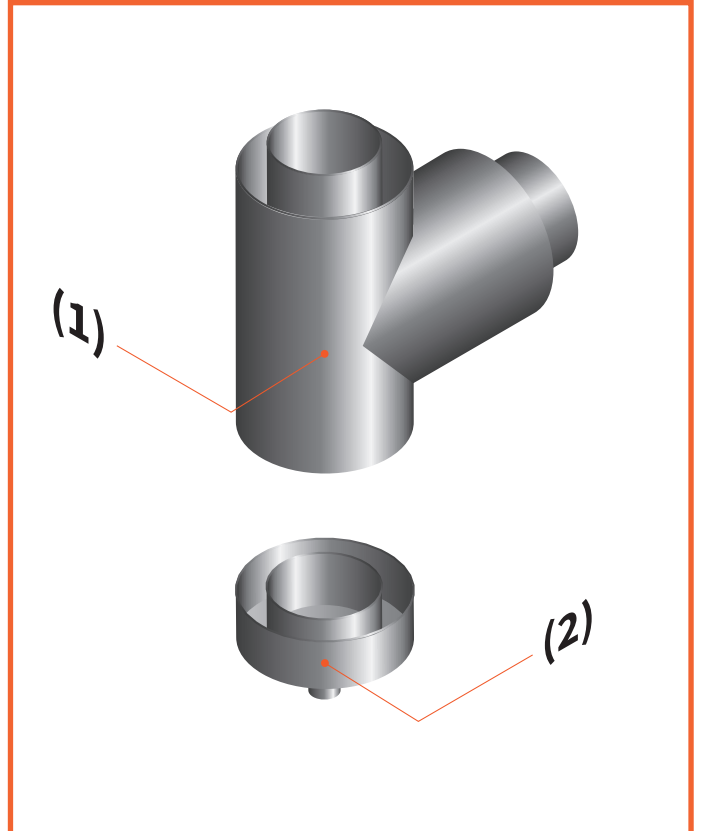

Figure 3.18 - Parts necessary for condensation tap

4 ADJUSTING THE POWERFAN

The setting of the PowerFan is done with the speed controller. With this podmeter you set the resistance of the motor. The lower the resistance, the faster the motor runs. This controller and the indicator lights are located on the PowerFan itself. A cover must be removed for this. Make sure that this cover can be reached at all times (See **Figure 4.1**)

4.1 Set initial position

See **Figure 4.2**

- Position 0 - Motor runs slowly.
- Position 12 - Motor is running at full power

4.2 Start

When the fireplace is started, the fan runs at high speed for 5 seconds, after which a signal is sent to the control cabinet and the speed drops audibly. In this position the 2 green LED lamps are lit and one is flashing.

LED is blinking

The fan checks the system for correct operation for 60 seconds. If the system works properly, the blinking stops and the LED stays green

LED flashes red

If the green light does not stop blinking or changes to red, increase the fan speed by 1 step and observe the waiting time of 60 seconds again.

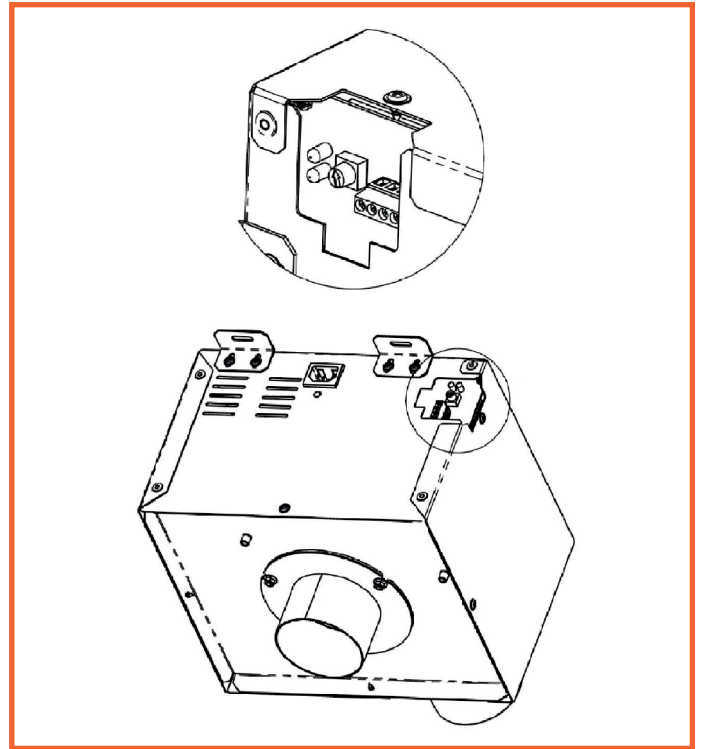

Figure 4.1 - Service cover PowerFan MkII

Please note

To increase the fan speed:

- Turn the speed control clockwise.

To reduce the fan speed:

- Turn the speed control counterclockwise.

Tip: For larger fires with more input, you may start adjusting the podmeter from 6 or higher. This will save some time during installation.

4.3 Fine-tuning

When the flames are satisfactory, increase the speed (if desired) by one more step to take account of extreme weather conditions such as wind. This prevents the fire from being switched off preventively, which is experienced as a nuisance.

Note: Only after 20 minutes can you assess the flames correctly. Take this time into account for the first installation. The fan can switch off before the 20 minutes have elapsed.

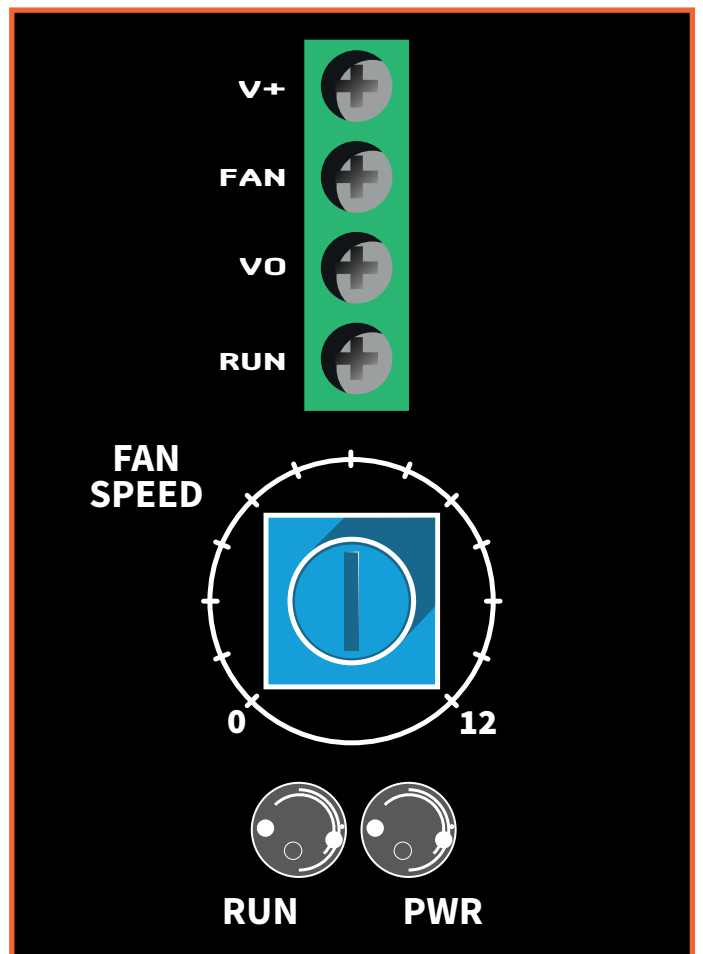

Figure 4.2 - Speed pod meter PowerFan

5 FUNCTION OF THE REMOTE

By pressing the "Start button" (top left button) the fireplace and the PowerFan will start simultaneously.

Note: The thermostat and pilot flame function are canceled with installations in combination with a PowerFan. All other functions on the remote will function normally, as described in the user action. See the user- and installation manual for the fireplace.

Figure 5.1 shows an example of a ten-button remote for Element4 fireplaces. The thermostat function (third button from the left) is cancelled.

6 TECHNICAL DATA

The following specifications apply to every Element4 PowerFan MkII

Applicable for fireplaces	≤ 25Kw
Power Supply	230V
Air flow	165m ³ /hr
Noise level	≤ 38dB at 1 meter distance
Inlet current	230V 50Hz
	0.4A
Maximum output pressure	30 Pa
Maximum flue temperature	450°Celsius

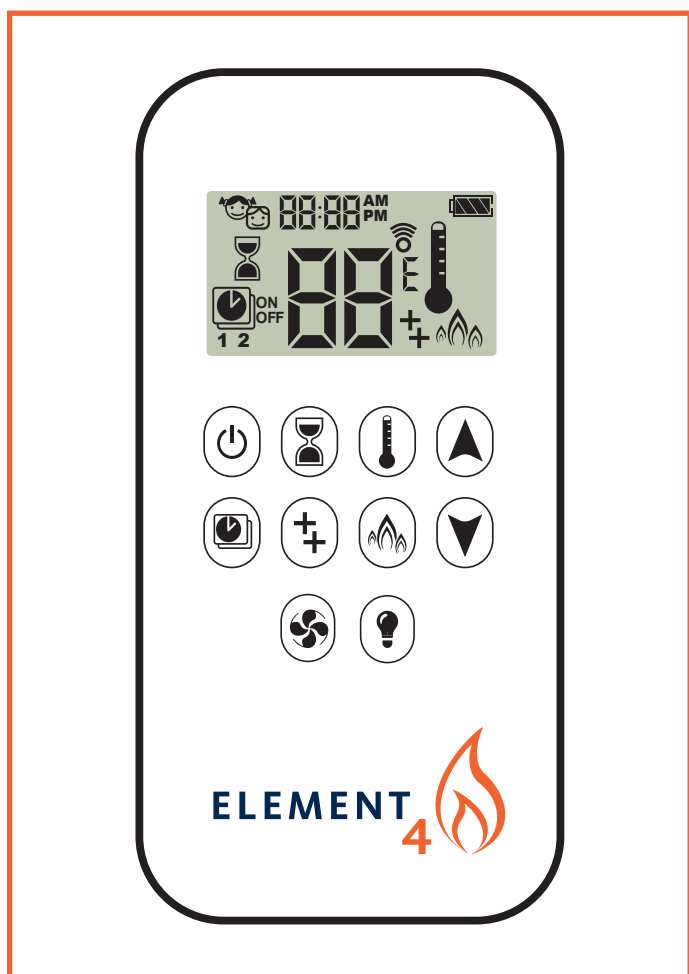

Figure 5.1 - Ten button remote Element4

7 TECHNICAL DRAWINGS

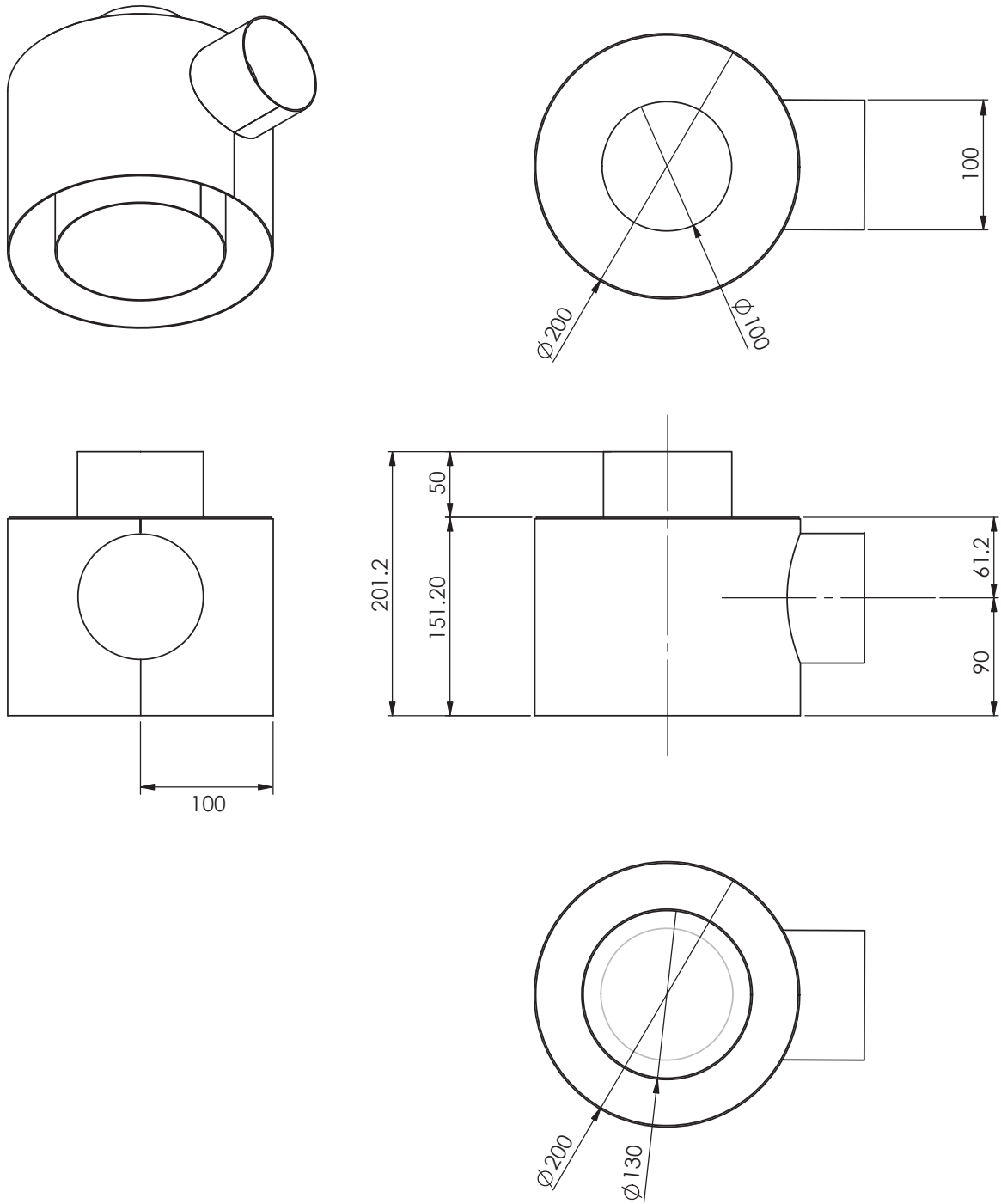

Figure 7.1 - Dimensions of the adapter

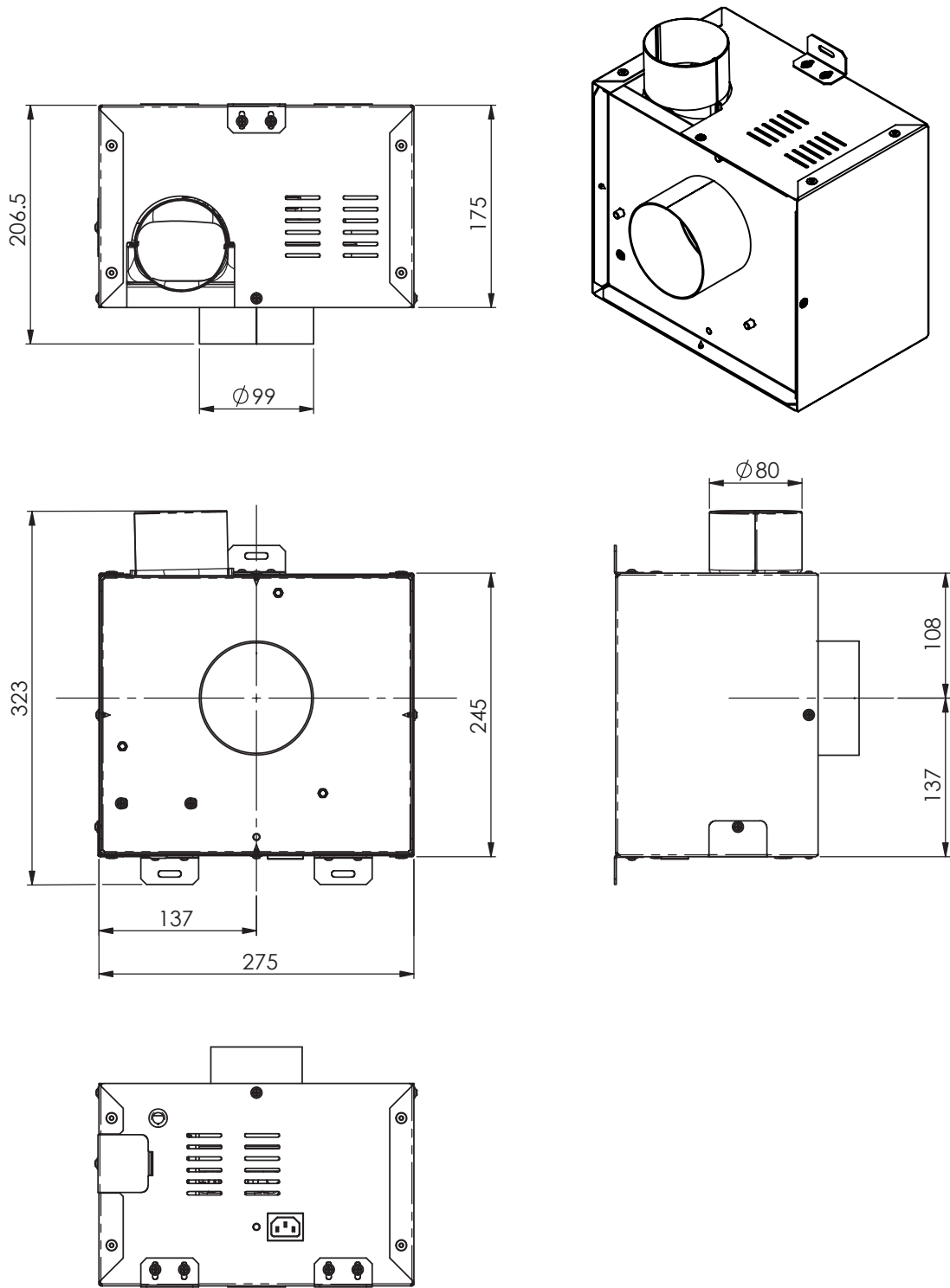

Figure 7.2 - Dimensions PowerFan MkII



ELEMENT 4 B.V.

Paxtonstraat 23
8013 RP Zwolle
The Netherlands
Info@element4.nl
www.element4.nl

RELEASE DATE | 26/01/22