

ELEMENT

GAS FIRES

4



INSTALLATION MANUAL

CUPIDO 60 & CUPIDO 70
CONVENTIONAL FLUE FIRES



PLEASE LEAVE THESE INSTRUCTIONS BEHIND WITH THE DEVICE



DO NOT USE THIS PRODUCT AS A PRIMARY HEAT SOURCE

CONTENTS

1 CE STATEMENT	4
2 IMPORTANT SAFETY INFORMATION	4
3 WARRANTY	5
4 REMOTE CONTROL WITH FULL ELECTRONIC IGNITION	6
4.1 Adjusting the communication code	6
4.2 Igniting the pilot light	6
4.3 Igniting the main burner	6
4.4 Switching off the fireplace	6
5 INSTALLATION PREPARATION AND - INSTRUCTION	7
5.1 Relevant norms and guidelines	7
5.2 Attention points gas fireplace	7
5.3 Attention points gas connection	7
5.4 Requirements flue and wall terminals	7
5.5 The chimney	7
6 FIRE SAFE INSTALLATION	8
6.1 Fire safety device set-up	8
6.2 Appliance Fireplace Installation	8
6.3 Building the Fireplace	9
6.4 Flue Connection	9
6.5 Additional notes	10
7 ATTENTION POINTS GAS FLUE	11
7.1 Installation of flue material	11
8 INSTALLATION CHECK AND FIRST USAGE	11
8.1 Renovation/new construction	11
8.2 Checking the gas lines	11
9 ELECTRICAL CIRCUIT	12
9.1 Domotica	12
9.2 Element4 ProControl App.	12
10 MAINTENANCE INSTRUCTION	13
10.1 Maintenance in the combustion chamber	13
10.2 Cleaning the glass	13
11 DECORATION ARRANGEMENT	15
12 USER INSTRUCTION	16
12.1 Hand over to the customer	16
12.2 Maintenance instructions for the installer	16
12.3 Anti-reflective glass	16
12.4 Ceramic parts	16
12.5 Replacement of parts	16
12.6 Packaging materials	16
13 COMMISSIONING THE APPLIANCE	17
13.1 Pilot Ignition Check	17
13.2 Main Burner Check	17
13.3 Pressure Check	17
14 SERVICING	17
14.1 Cleaning the Ceramics	17
14.2 Servicing the Burners	17
A FIRST AID FOR MALFUNCTION	18
B ERRORS CODES PROCONTROL APP	22
B.1 Messages shown in app	22
B.2 Messages shown in remote	23
C FAULTS AND ERROR CODES IN THE REMOTE	24
C.1 F41 error	24
C.2 Router information	24
D LOCATION TERMINAL	25
D.1 Terminal location with vertical exhaust (B11)	25
E TECHNICAL DATA	26
F ECODESIGN	27
F.1 Ecolabels	27
G DIMENSIONAL DRAWINGS	28

1 CE STATEMENT

We hereby declare that the design and construction of the Element4 gas appliances are complying to the essential demands and regulations for gas products.

Product:

- Open gas fireplace, local spaceheater

Model:

E4-26

- Cupido 60 CF

E4-27

- Cupido 70 CF

Applicable EG-guidelines: (EU) 2016/426 (GAR)

Applicable harmonized norms:

- NEN-EN-613
- NEN-EN-613/A1

This declaration loses its validity when changes to the device are made without the written permission by Element4. You can ask for a copy of the test certificates of all models via our general e-mail adress, which is found on the back of this manual.



J. Kempers
CEO

2 IMPORTANT SAFETY INFORMATION

The fireplace may only be installed by a qualified installer/dealer, following these installation instructions. We advise you to read these instructions properly, before commencing the installation of your device.

Before installation check the device for transport damage and inform your supplier immediatly if damage is found.

Check the data on the dataplate. The gas type and pressure should check out with those locally available. The data plate is mounted to the device. Make sure it is accessible at all times.

This device is design to be used with natural gas or LPG. The device can only be used with the type of gas specified on the data plate at the time of purchase.

The device may never be used without the glass or when glass is broken. Before replacing the glass do not fire your appliance. Doing so may result in warpage of metal parts.

Parts are only to be changed with original parts by the original manufacturer.

The device is provided with a special set of decorative materials. Do not place any extra imitation logs or decoration material on the burner or in the combustion chamber. See chapter 11 for an instruction on how to arrange the decoration materials properly.

The glass and frame on this appliance acts as a fireguard conforming to BS: 1945 – 1971 and satisfies the HeatingAppliance (Fireguards) regulations 1991. No part of the window or frame should be permanently removed. It does not give protection for young children aged or infirm, extra guarding (conforming to BS8423: 2002) should be considered so the special hazards that exist in nurseries and other places where there are young children, aged or infirm persons are minimized.

The heat that is coming from the device may effect the materials in its surroundings. Always take into account to correct safety distances. For more information see **CHAPTER 6**.

This device makes use of an atmospheric pilot safety, meaning it will automatically shut down when dangerous levels of carbonmonoxide are detected in the combustion chamber.

This appliance is rated at 6.9kW, and as such needs no additional ventilation. However an adequate supply of fresh air to maintain temperatures and a comfortable environment is recommended.

3 WARRANTY

NB: Should a problem occur, that you are not able to fix yourself with the help of the support in Appendices A to C, please contact your installer or dealer.

The Element4 devices on which this warranty is applicable are made of high quality materials. Should any problem or defects still occur the following provision are in effect;

1. Before any installation, the installer will ensure himself of the good quality and operation of the flue channel. The gas fireplaces are to be installed by a competent installer, according to the rules and regulations that are applicable in the country (or even region) of installation and those as described in this manual.
2. There is a warranty period of two years for all Element4 devices, starting from the moment of purchase. The date of purchase should be mentioned clearly on the purchase invoice.
3. The ceramic glass is not included in the warranty, as are the physical or chemical outside influences during transport, storage or montage.
4. If a malfunction should occur during warranty period that is a consequence of an assembly error or material defect, Element4 will provide a free replacement part to the installer, without compensation for disassembly or montage.
5. In case the installer is not able to fix the problem himself, a request can be made to Element4 to do it for him, as long as the service can be done within the borders of the Benelux.
6. Only after consultation up front, the device or loose parts can be send for check up or replacement. These goods are the be send with the necessary warranty documents and the date of purchase.
7. When a house visit should occur for service purposes by Element4 (within the borders of the Benelux) during warranty period, the right documentation (i.e this page and a proof of purchase) should be available.

For a service provision to house, outside the warranty period, the following costs are being charged:

- Material costs
- Working hours
- Call-out costs

The warranty is not applicable in the following cases:

1. When one of the previous points is not met
2. When changes are made, of which Element4 is not made aware / has approved of upfront
3. When device is not installed and/or used properly according to the installation manual.
4. When other than the prescribed decoration material is used.
5. When the device is installed (partially or fully) with other materials than prescribed in this manual.

4 REMOTE CONTROL WITH FULL ELECTRONIC IGNITION

The fireplace is operated using a remote control or the Element4 Puck (Fig. 4.1), connected to a receiver (Fig. 4.2).

The receiver is powered by 4 pen lite (type AA) batteries or a 6V adapter; 2 penlight batteries (type AAA) are used for the remote control. The life of the batteries is about a year with normal use.

4.1 Adjusting the communication code

Before using the appliance, a communication code must be set between the remote control and the receiver. The code is chosen at random from the 65000 available codes. Therefore there is a slim chance that other remotes in your area use the same code.

Please do the following

Press the reset button on the receiver until you hear two beeps. After the second longer signal, let go of the reset button (Fig. 4.2).

Within 20 seconds, press the down arrow on the remote control until you hear a sound signal. This is confirmation of the proper communication.

4.2 Igniting the pilot light

Check that the control knob (A) is in the ON position (Fig 4.3). Press the button on/off button of your remote control and continue to hold down (3 to 5 sec.) until you hear two short beeps.

The ignition sign will appear at the top of the screen (Fig. 4.1) Now release the button. The ignition procedure is started.

NB: If the pilot light doesn't remain lit after 3 attempts you must turn off the gas tap and warn your installer.

4.3 Igniting the main burner

After starting the pilot, knob (B) will automatically rotate counter clockwise and the main burner will start burning (Fig 4.3). Always wait 5 minutes after killing the pilot light before you start the pilot flame again.

NB: The pilot light must ignite the main burner, evenly and without a thud. If it does thud, close the gas tap and warn your installer.

4.4 Switching off the fireplace

You switch off the fireplace by pressing the on/off button, this also turns off the pilot light! For a detailed description of the remote control, please refer to the user manual which is included with the fireplace.

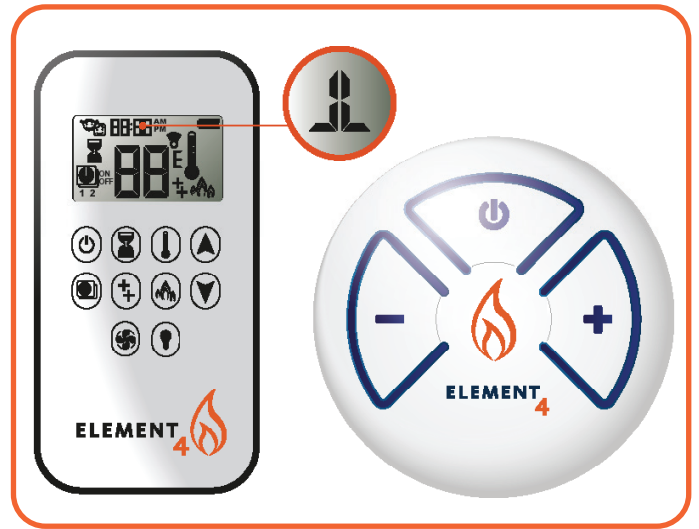

Figure 4.1 - Remote and ignition sign

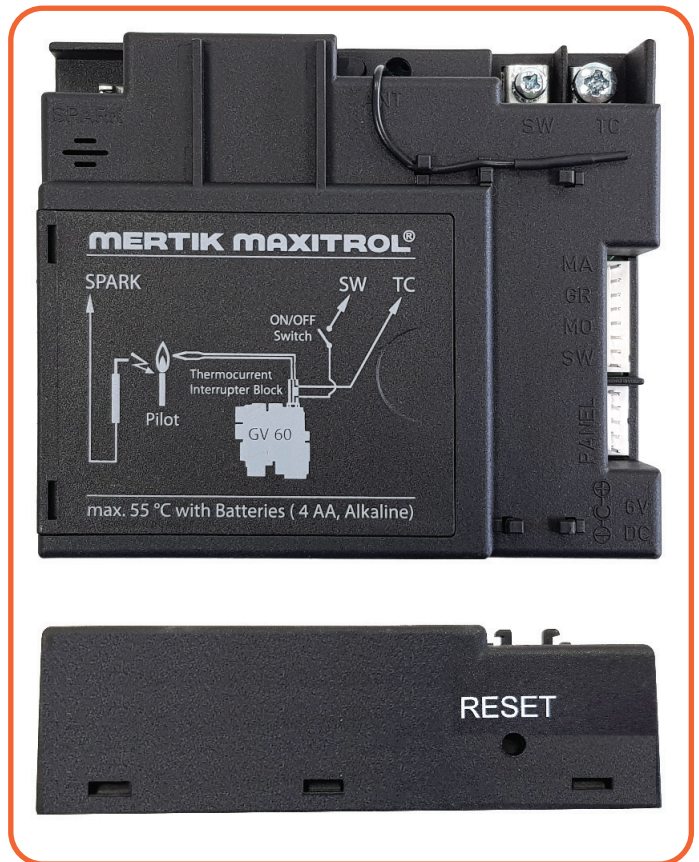

Figure 4.2 - Receiver

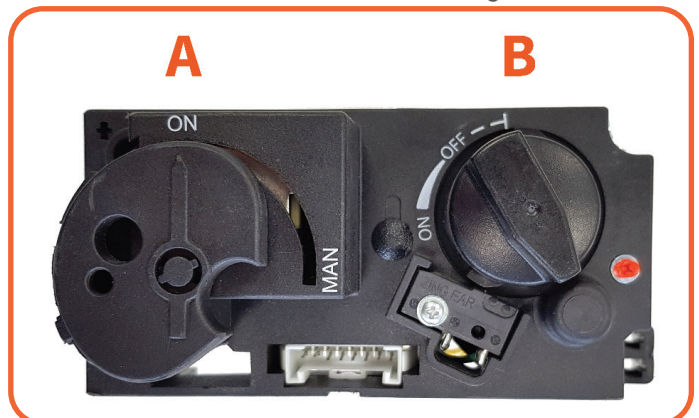

Figure 4.3 - Gas Block

5 INSTALLATION PREPARATION AND - INSTRUCTION

The device is developed, tested and approved conform the applicable standards for the usage, the performance and safety of the product. The installation of your device must apply to the current building prescriptions. We advise to make use of a qualified gas installer for the installation of your device. The installer can provide you with all information regarding the safety regulations of the installation.

5.1 Relevant norms and guidelines

The installation must be carried out in accordance with the following regulations

- Department of the Environment, the Building Standards (Scotland) (Consolidation) Regulations issued by the Scottish Development Department.
- BS 5440 part 1
- BS 5871 part 2
- BS 6891.

In the Republic of Ireland the installation must also conform to the relevant standards, particularly in regard to flue sizing and ventilation. Refer to documents;

- IS813
- ICP3
- IS327
- Any other rules in force.

This appliance must be installed in accordance with the rules in force and used only in a sufficiently ventilated space, and is intended for use on a gas installation with a governed meter.

5.2 Attention points gas fireplace

This device can be place in a new or existing situation. The device cannot be installed in a fully enclosed or mechanically ventilated room without extra ventilation.

Before installation of these appliances, the area into which the fire is to be fitted must be cleared of all debris (including dust), in particular combustible material.

5.3 Attention points gas connection

The gas connection should apply to the local norms in force. Calculate the diameter of the gas flue, such that no pressure loss is occurring in the pipes. Place a shut-off valve in the near vicinity of the device. Position the gas connection, such that it is always accessible for service purposes.

The gas block and electronics can only be reached from the inside of the fireplace. The front of the fireplace offers a slot, under the lower trim, through which equipment can be put, to test the fire when burning.

To open and attach the equipment, the fire needs to be opened according to the steps explained in **CHAPTER 10**.

Also the decorative materials and the burner grate need to be removed. **CHAPTER 11** shows you how the decorative material must be placed back in the fire. It is recommended that these tests are done during maintenance to avoid any extra opening of the fireplace.

5.4 Requirements flue and wall terminals

The European CE-marking for the device is only applicable to the flue materials specified by the supplier. The device must be installed with the stainless steel flue material.

Examples of approved flue brands are:

- US van Metaloterm/On Top
- Poujolat
- Jeremias

The usage of other stainless steel material is only permitted when it has the same technical specification as the previous mentioned systems. Only when these materials are used a good and safe performance can be promised by Element4.

5.4.1 Flue classifications

The flue channel works as a roof terminal (B11), as well as flex pipes in an existing channel (B91). Please check, whether the desired terminal complies with the regulation for your situation (See: **APPENDIX D**).

It is possible that an extra restriction plate is necessary when the terminal is within two meters from the ground.

5.5 The chimney

Before the chimney is installed, we advise an operation test with the device. The chimney should be constructed from non-combustible materials and cannot rest on the mounting frame. Always use a chimney iron, when using bricks or cell concrete.

The chimney ventilation should meet the local norms. A well ventilated chimney makes sure the temperature is regulated to ensure a proper operation of the electronics and the gasblock. Furthermore, good ventilation helps to keep the convection air under 85°C.

NB: Make sure that it is possible for the convection air to flow away from the chimney. When closing off the existing chimney, ensure proper ventilation slots are installed in the chimney breast to ensure that the heat is diverted.

More on chimney construction in **THE NEXT CHAPTER**.

6 FIRE SAFE INSTALLATION

To install a gas fireplace as safely as possible, several installation preparations need to be made. This overview can be used to assure the fire safety of a conversion of a fireplace.

Before commencing Installation, confirm that the details on the appliance data plate correspond to the local distribution conditions, gas type and pressure to which the appliance is to be installed.

Ensure that gas supply and supply pipe is capable of delivering the required volume and pressure of gas and is in accordance with the rules in force.

6.1 Fire safety device set-up

Install the device such that there are no flammable materials around the device or chimney. The device must never be placed against a back wall of flammable materials.

Flammable materials, such as wood, can combust at a temperature of 85°C. At high temperatures this can happen within several minutes (over 200°C) or at lower temperatures (more than 85°C) this may occur over a period of weeks.

A gas fireplace can achieve temperatures of over 200°C. Therefore one should use only non-flammable materials around the fireplace and in the cove.

It is important to follow the installation regulations below carefully. When the regulations are insufficiently- or not provided with the aspects of fire safety, the instructions according to NPR 3378-20:2010 are leading.

6.2 Appliance Fireplace Installation

6.2.1 Gas Connection

Determine the position required for the appliance. Create a gas connection for the appliance in (approximately) the correct location for the gas controls. This appliance has a gas inlet connection of Ø 8mm.

The gas controls are connected to the Burner of the appliance. The gas block itself is located securely under the fireplace and can only be reached from the inside.

NB: To be able to do maintenance to the fireplace, it is recommended to **not connect the gas block with a rigid gas line**, but to make use of a small piece of flex line first.

6.2.2 positioning the fire

This appliance has fully adjustable legs, these must be set to the desired length before the flue position is finalised. Fine adjustment of the legs is available via the adjustable feet. Do not make any adjustments to the appliance, except the leg length.

The brackets supplied may be used for securing the appliance to a rear wall.

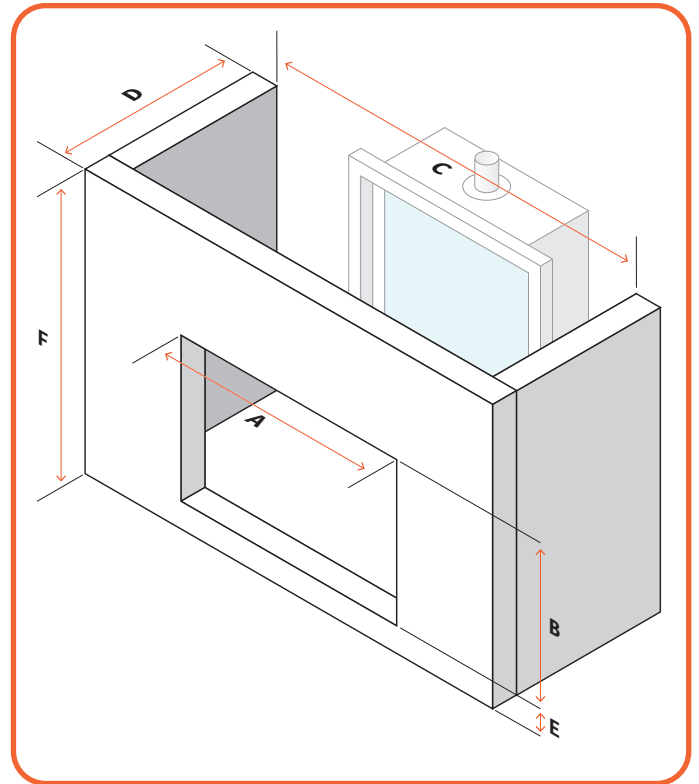

Figure 6.1 - Studwork construction around the fireplace

Appliance	A _{min}	B _{min}	C _{min}	D _{min}	E _{min}	F _{min}
Cupido 60 CF	680	587	820	351	149	884
Cupido 70 CF	724	690	864	351	149	988

Table 6.1

6.4.4 Aeration round the fireplace

For a conventional flue fireplace there is only an exhaust flue pipe. one may choose between a flue size of Ø100mm or Ø125mm.

A third option that is only possible for inset fires in an existing chimney is to close the top of the fireplace and open up the slot at the back of the fireplace. This slot will function as an exhaust and the chimney will cause natural flow.

The fresh air is taken, from the front of the fireplace through the slot in the bottom trim, or via the convection air in the chimney breast via the bottom of the fire. This air will heat up by the fire.

IMPORTANT!
Take into account enough room for convection air to leave the chimney breast! Either the air should be able to leave the chimney between the exterior or the flue pipe and the existing chimney, in the case of a inset fire, or precautions must be taken in the form of a convection slot in the chimney breast.

Not doing this may cause rips and breaks of the chimney or the transfer of heat may cause a fire. Even non-combustible material will eventually cause a possible heat bridge to combustible materials!

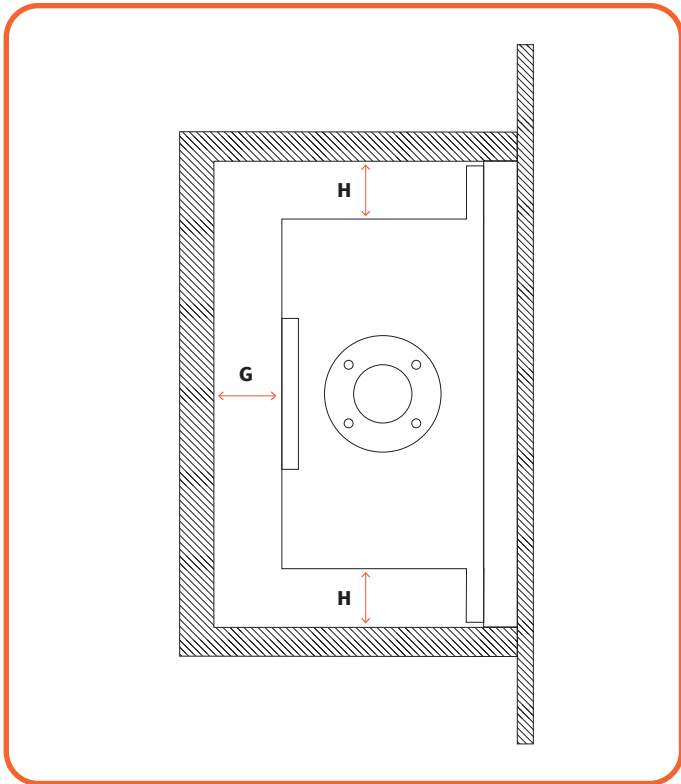

Figure 6.2 - Top view of the fireplace installed in the chimney

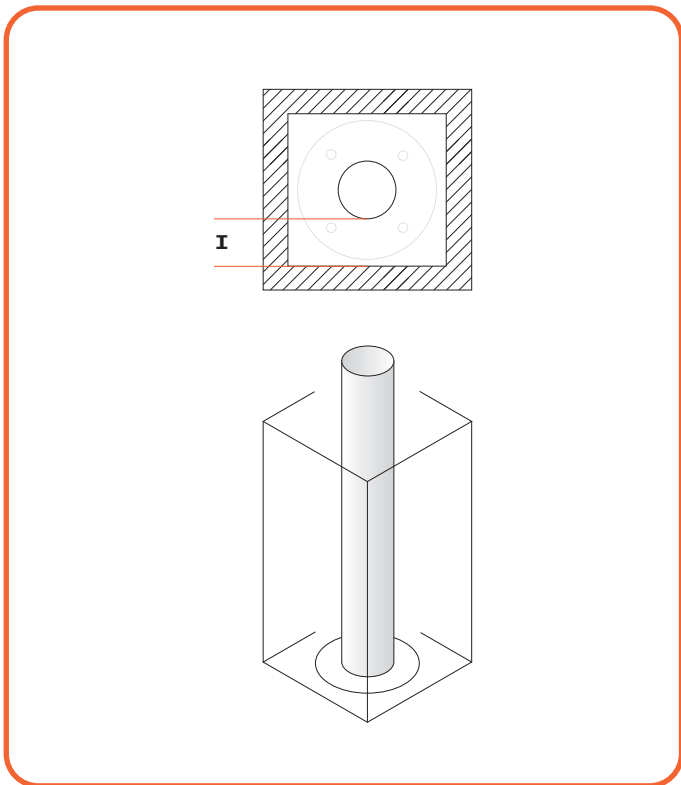

Figure 6.3 - Area around the flue pipe.

6.3 Building the Fireplace

Construct a studwork fireplace to the desired sizes, minimum sizes are shown in **figure 6.1**. Any combustible material used to construct the Fireplace must not be closer than the minimum dimensions quoted in **table 6.1**.

The appliance should be fitted with a minimum clearance of 100mm (**G** in **figure 6.2**) from any combustible objects or materials; this includes any combustible materials used for the fireplace construction. This clearance distance can be reduced to 50mm if a cement Board, e.g. promatec, of minimum thickness 12mm is used. This cement board will act as a thermal break. The clearance distance of the flue from combustibles must not be less than 75mm (**I** in **figure 6.3**). Cement board can be used directly against the Frame Face on the appliance.

Do not use insulation material (or other) to pack the void around or above the appliance.

6.4 Flue Connection

6.4.1 General notes

This appliance may be installed with a roof termination with a rigid or flexible pipes, or in a masonry chimney class 1 or class 2 and without lining the flue. The flue system must be constructed from the appliance upwards, with all joints being fully locked and sealed.

6.4.2 Timber Frame Construction

Whilst it is possible to install room-sealed appliances in timber frame properties, great care needs to be taken to ensure that the flue assembly does not interfere with the weatherproofing qualities of any outer wall which it may penetrate. Before attempting this work, it is advisable to consult with a qualified installer.

6.4.3 Carport or Building Extension

Note: A covered passageway should not be treated as a carport. Flues should not be sited in a covered passageway between properties.

6.5 Additional notes

6.5.1 Ventilation

This appliance does not need extra air vent in the room in which the fireplace is set up. However an adequate supply of fresh air to maintain temperatures and a comfortable environment is recommended.

6.5.2 Floor protection

The temperature of the floor under the device needs be less than 85°C and the floor of the conversion around the fireplace is to be constructed of non-flammable materials. If necessary the floor is to be covered with an insulation layer to protect it from unauthorized temperatures.

6.5.3 Radiation

When the fireplace is turned on, heat radiation will escape through the ceramic glass and will heat up the environment. Therefore it is important that a minimal distance between the ceramic glass and any flammable material in front of the fireplace is one meter.

If a shelf is to be fitted above the fireplace opening, a gap of 150mm minimum should be left between the opening and the shelf. See **figure 6.4** and **6.5**.

6.5.4 Electrical pipes

The conversion has to be free of the usual electric installation pipes, if these are not protected against temperatures over 30°C by the necessary precautions. Special pipelines with an heightened heat resistance are permitted.

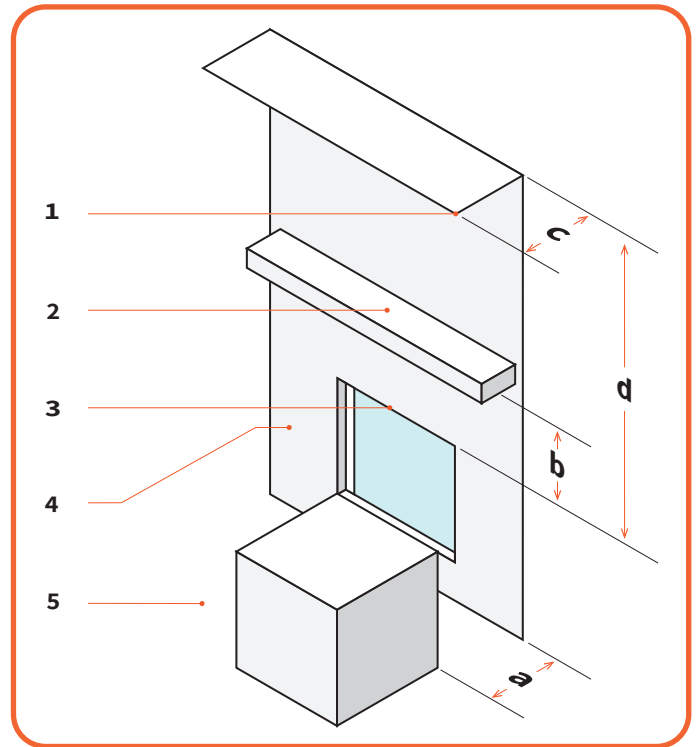

Figure 6.4 - Isometric overview of fireplace mantel

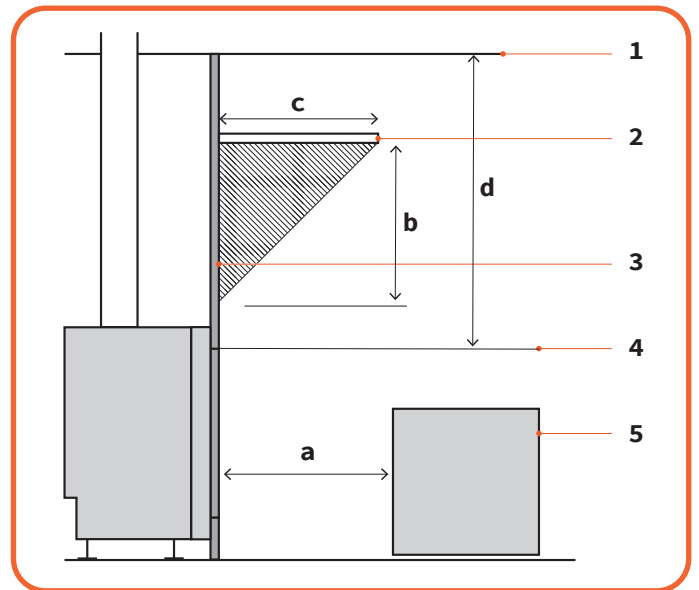

Figure 6.5 - Side view of fireplace mantel

Description	Distances
1 Ceiling	
2 Mantel piece	
3 Front face (e.g. cement board)	
4 Top of fireplace opening / glass	
5 Furniture / Combustible object	
a Minimal distance to combustible object	1 meter (min.)
b Mantel height (from Fireplace opening)	150mm (min.)
c Mantel projection (from face of front)	
d Distance to ceiling	1 meter (min.)

Table 6.2

7 ATTENTION POINTS GAS FLUE

To guarantee the fire safety regarding your flue gas configuration a casing is necessary. For this case non-combustible materials should be used. Make sure to ventilate a shaft and never to insulate it, to make sure the hot air is able to get away.

Every transit or terminal should be made such, that the warmth-insulation and non-combustability is guaranteed, according to the building regulation.

7.1 Choosing the correct flue spigot

For the conventional flue fireplaces of Element4 there are three flue spigots available, respectively;

- Flue size 100mm
- Flue size 125mm
- Rear flue

For the 100mm and 125 mm an adjustable spigot is available that can be mounted on the top side of the fireplace. These spigots are compatible with the tested flue materials as mentioned in **CHAPTER 5.4.**

For the rear flue, no additional flue material is necessary. The installer can choose to take away the plate on the back of the fire and cover the top hole, to be able to place the fireplace directly into an existing chimney.

7.2 Installation of flue material

Follow the following instructions for the installation of flue materials;

- Drill a hole of 100/125 mm for the roof transit and an additional 10mm around.
- Keep a distance of at least 5 mm between the outside of the pipes and the wall or ceiling (**Figure 6.3**).
- Provide a (fire) safe transit construction in wall, floor or roof sheeting
- Build the system from the fireplace.
- Assemble pipes in the correct direction.
- Make sure the tubes are sufficiently braced, so the weight of the tubes are not supported on the hearth.
- The pipes could come loose due to expansion and cooling down. It is recommended that a chuck parker be used in places that are inaccessible after installation.

7.2.1 Adapting the length of the chimney

Not all parts can be adjusted! To fit the drainage system correctly, you are to use an adjustable fitting. You can use an adjustable pipe and roof fitting.

8 INSTALLATION CHECK AND FIRST USAGE

8.1 Renovation/new construction

When firing up the device for the first time, make sure the device burns for several hours on the highest level, to ensure the lacker to harden. Make sure the device is ventilated enough so the possible released fumes are being abducted. We advice to be as little in the room as possible during this process.

Because a fireplace is a heat source, natural convection will occur around it. Solid particles in the circulating air may burn and settle down on cold surfaces, causing discoloration. Discoloration is an annoying problem and it is difficult to solve.

These particles can come from construction moisture or cigarette smoke, but also they might be volatile components in paint, construction materials or carpeting. For newly constructed chimneys or after a big reconstruction, it is advised to wait a minimum of six weeks before firing a fireplace.

8.2 Checking the gas lines

To be able to check on the gas lines, it is necessary to have the right equipment. If necessary take out the glass of the device and use the measuring point (see **figure 8.1**), to check the supply pressure on the gas pipes.

- A = Supply pressure
- B = Burner pressure

Make sure the cables of the ignition are hanging loosely under the device, to ensure a good ignition.
 Remove any tie wraps or other cable binders.
 Check the pilot for obstructions
 Check the air tightness of the gas lines.
 Technical specifications can be found in **APPENDIX E.**

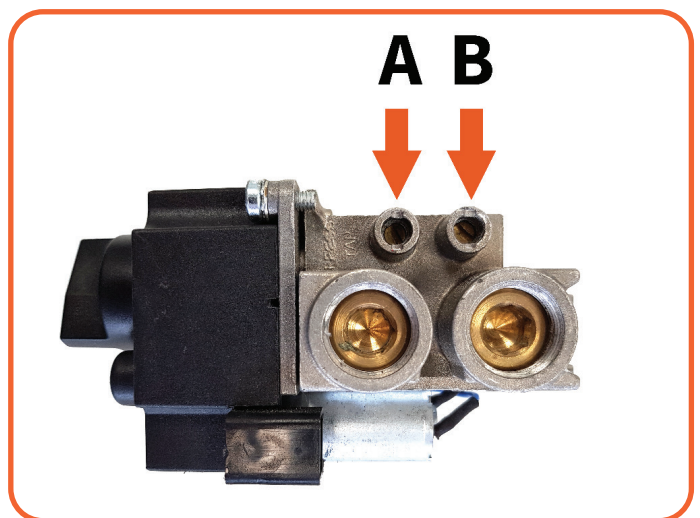

Figure 8.1 - Gas Block Measuring Points

9 MAINTENANCE INSTRUCTION

This part of the manual focuses on maintenance. To ensure the optimal flame picture of your device, an annual maintenance by a competent company or installer is prescribed.

9.1 Maintenance in the combustion chamber

During maintenance the glass windows of the fire need to be removed. To do this follow the following steps:

9.1.1 (Dis)assembly of the trims

For a tight finish of the fireplace, trims are available. During maintenance these trims must be removed, before the glass can be removed. Please follow these steps:

Disassemble

- Remove both the side trims. They cover up the window frame. (*Figure 10.2 & 10.3*)

Assembly:

- Put the trims back in reversed order.

9.1.2 Remove glass

To be able to clean the glass on the inside, one needs to remove the glass. To do this follow these steps:

- Check, whether the trims are removed in as in **step 10.1.1**.
- Remove the ropes holding the window in place. (See *Figure 10.4*)
- Put the suction cup on the glass and make sure it is properly vacuumed, so it will not come off. (See *Figure 10.5*)
- Lift the glass out of the lower glass rail and tilt it out through the opening, as seen in *Figure 10.6*.

NB: Put away the glass in a safe place, when you are not using it, to make sure it will not damage during maintenance. Remove the suction cup after putting away the glass to avoid tracing or stains.

9.2 Cleaning the glass

Keep in mind the following when cleaning glass:

- Always clean the glass at room temperature.
- Use cleaning supplies qualified by Element4.
- When you clean your Anti-Reflective glass, make sure you use this with the special Element4 cleaner, which is available only via Element4.
- Use only a microfibre cloth. Other materials such as kitchen towels, steel wool etcetera can cause scratches or damage the coating on the glass.
- Should there occur stains on the glass, remove them regularly, for the can burn the glass.

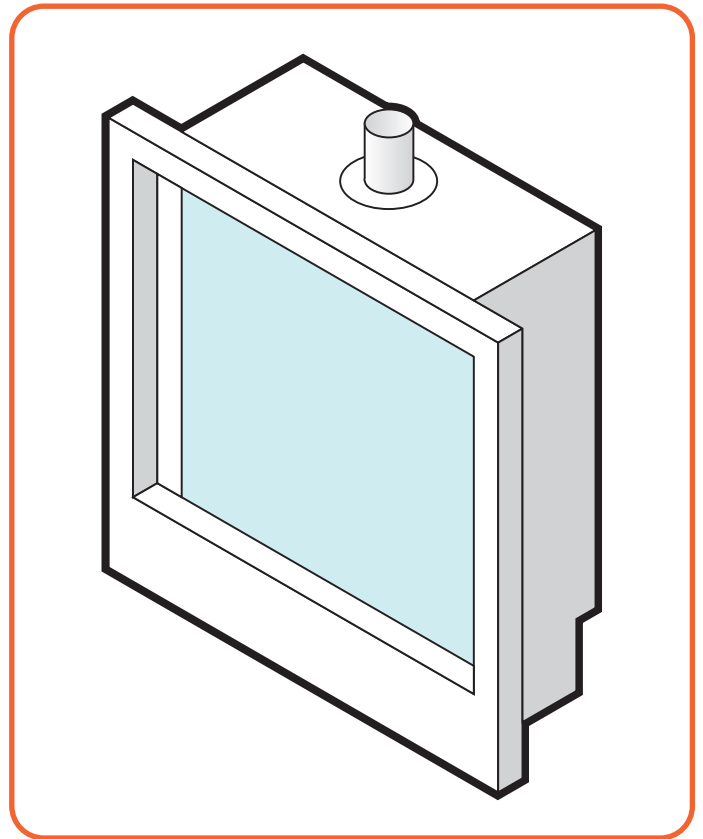

Figure 10.1 - Isometric view of the CF Cupido's

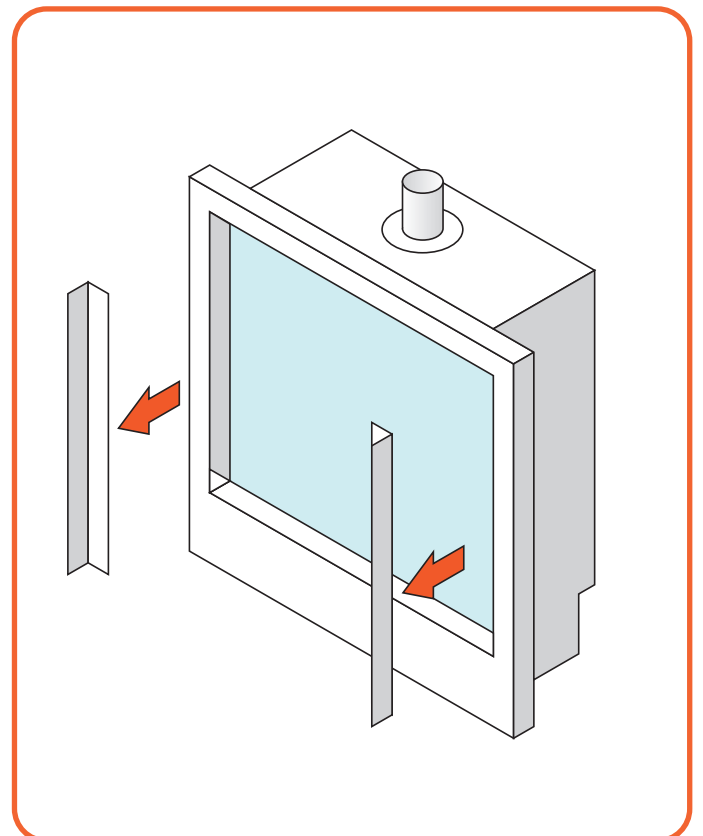

Figure 10.2 - Remove Side trims

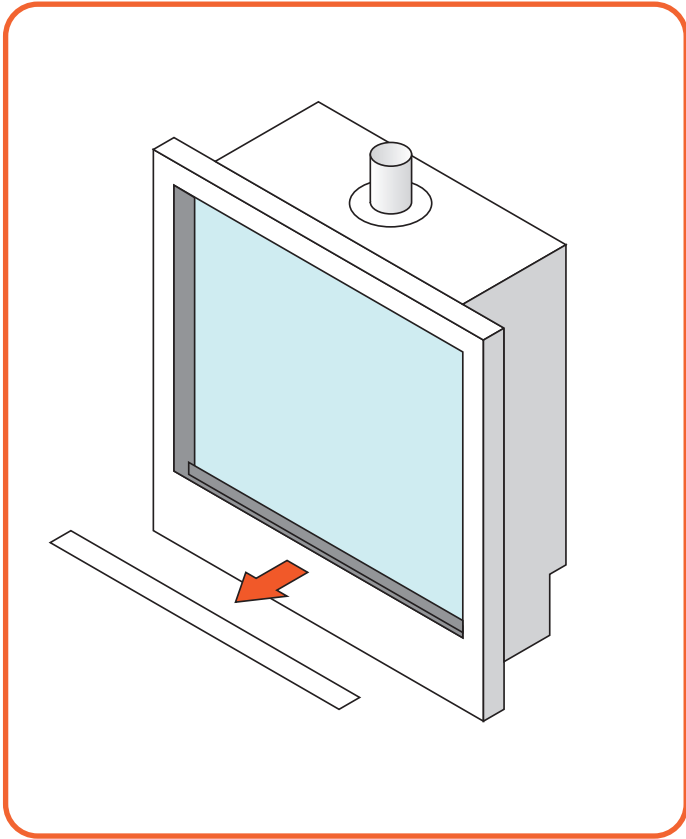

Figure 10.3 - Remove bottom trim

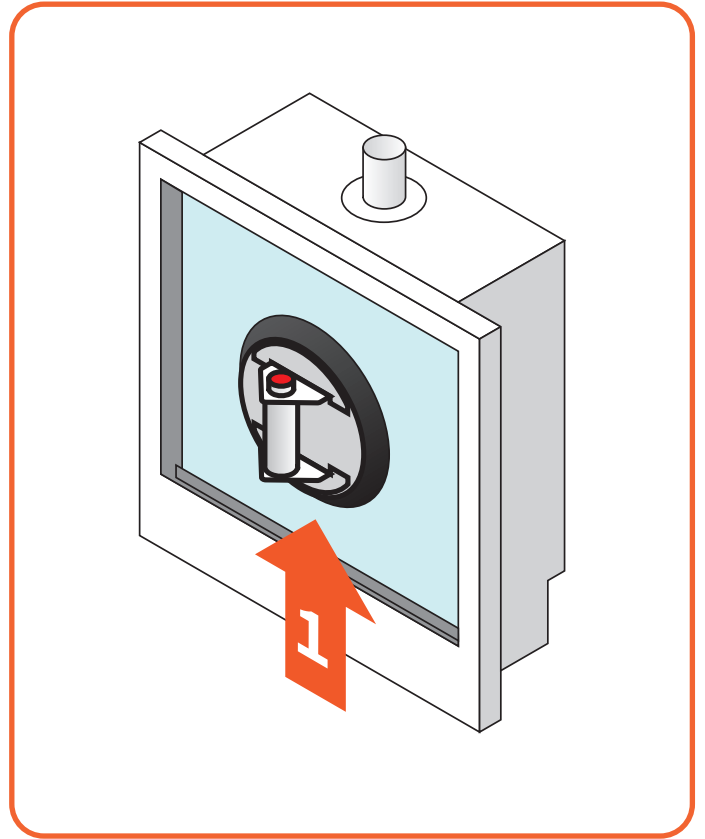

Figure 10.5 - Put on the suction cup and lift window

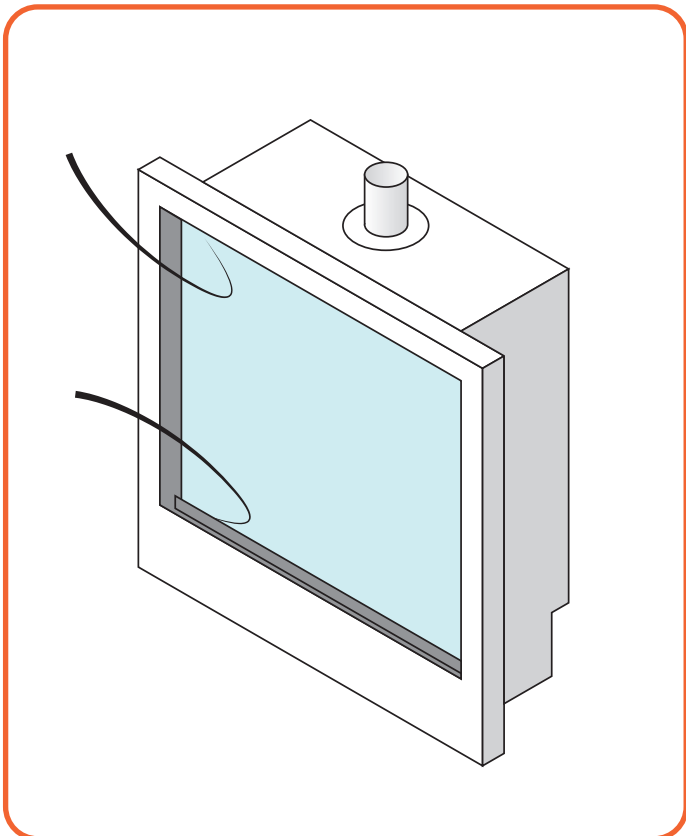

Figure 10.4 - Remove window ropes

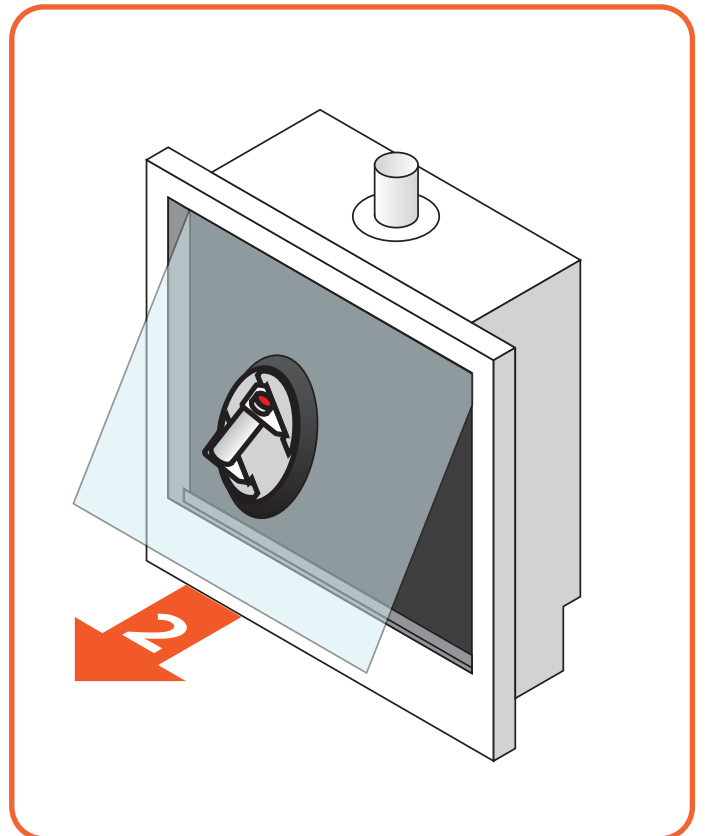

Figure 10.6 - Remove window by tilting

10 ELECTRICAL CIRCUIT

Figure 9.1 shows a simplified connection circuit for the fireplace. Every fireplace is provided with a main adapter.

#	Omschrijving
(1)	Gas Block
(2)	Receiver
(3)	Main Burner
(4)	Log Burners
(5)	Pilot set
(6)	Adapter 6V
(7)	Wifi-Box

10.1 Domotica

The receiver offers the possibility to be connected to a domotica system. A special connector is being supplied for this. Type: G60-ZCE

10.2 Element4 ProControl App.

It is possible to operate your device via smartphone or tablet with the ProControl App, available in the appstore on iOS and google play on Android.

The app has a user friendly, interactive layout and the design is adjusted for Element4 devices. Up to eight devices can be used with one app, in the situation that multiple fire are installed in the same location.

Another functionality of the app is to pre-set the temperature of you device, for a period of one week, to ensure yourself of an optimal desired room temperature. Also the device can changed between high and low flames and it features an eco-setting.

The amount of users, that can operate the device is unlimited, so every family member can make use of it, by easily making a personal account. By two-way communication, one can check on the device at any moment.

To use the app, the device needs to be provided with the correct receiver and remote combination.

Necessities for the installation of the ProControl:

- 220 volt electricty near the fire
- Wi-Fi code of the router
- Smart Phone or tablet
- ProControl manual

Should any problems occur you can always check **APPENDIX B**.

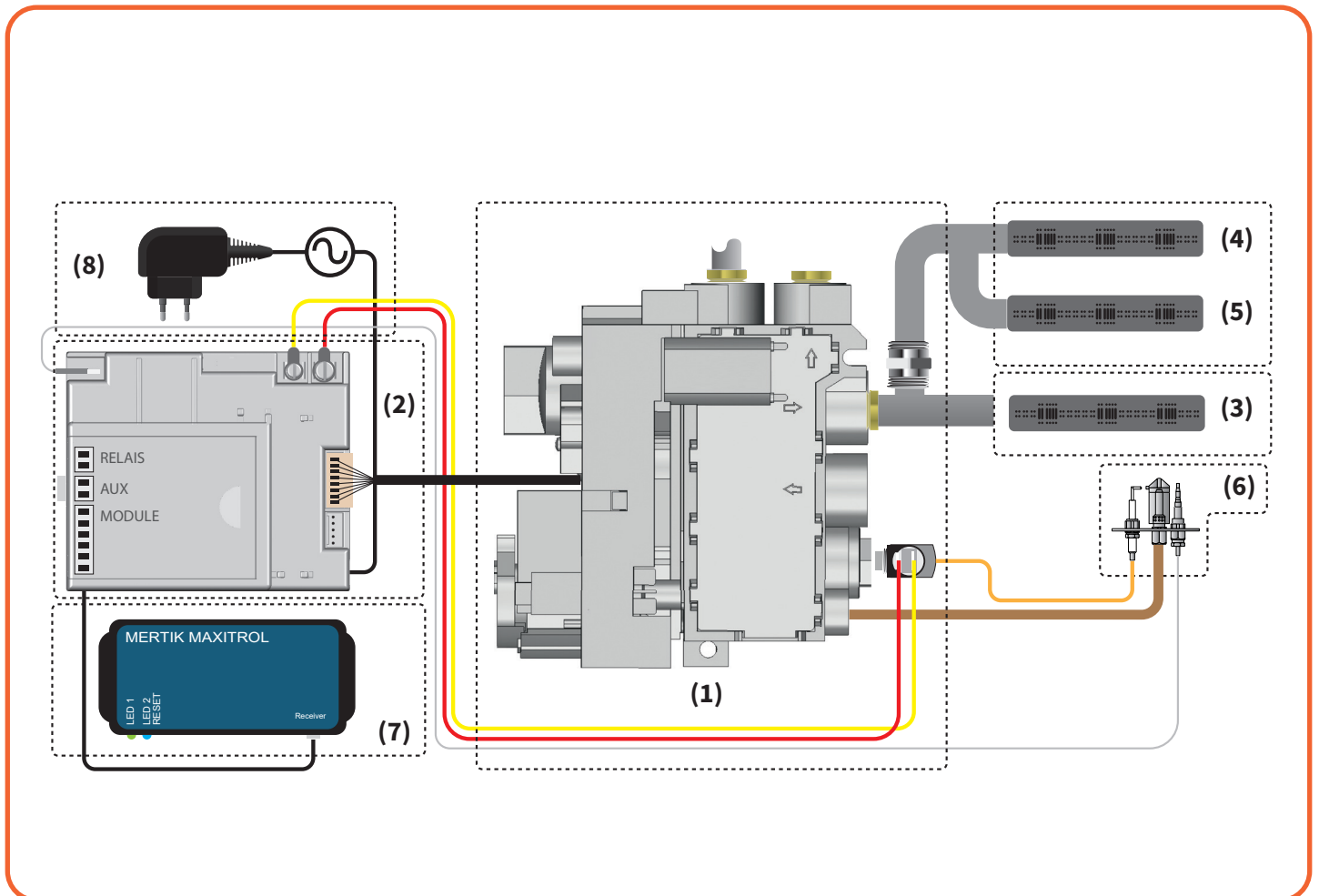

Figure 9.1 - Schematic Electronic Circuit

11 DECORATION ARRANGEMENT

Only the decoration ceramics supplied with this appliance are to be used. The ceramics must be laid only as shown on this page. Replacement parts are available from your dealer, but should only be installed by a qualified installation engineer.

An elaborate decoration instruction is found on the sheet in the logset that comes with the fire. These instructions show you how to decorate the fire step by step.

Position the decoration logs as shown on the image below.

Make sure that the pilot flame area is always free of any decorative material to make certain that the fire will ignite without problems.

Not doing so may cause the fire to explode on ignition!

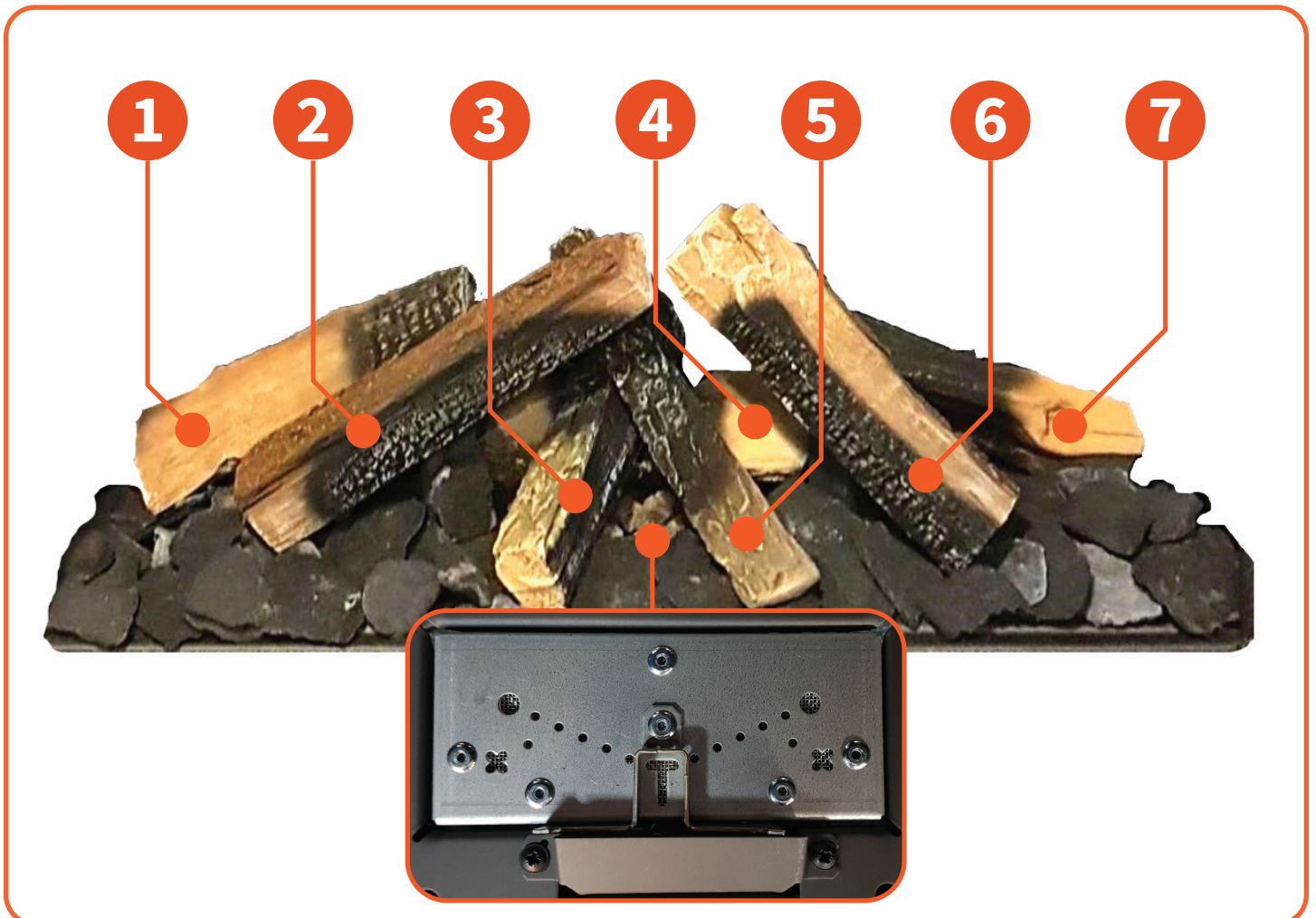

Figure 11.1 - Logset decoration instruction

12 USER INSTRUCTION

We recommend that you have the appliance inspected annually by a recognized installer to ensure safe use and a long service life guarantee.

12.1 Hand over to the customer

- User manual
- Installation manual
- Instruction card decoration material
- Suction cups
- Remote control

12.2 Maintenance instructions for the installer

Below is an overview of the minimum maintenance that must take place annually;

- Remove the glass plate and remove all ceramic parts.
- Remove any dirt on top of the burner with a vacuum cleaner and brush.
- Inspect the burner.
- Perform an ignition check.
- Check that the pilot light ignites the main burner free and unhindered by ceramic material.
- Perform a flame failure check

Maintenance on the burner should not be necessary. If this is the case, check the set pressure at the inlet to the burner. The correct pressure is stated in the back of this manual.

Wood arrangement

Brush the imitation logs and replace any broken or damaged parts (see earlier in this manual).

Next:

- Check the ceramic cord on the glass plate
- Reinstall the glass plate.
- Check the installation for gas leaks.
- Check whether the facade / roof outlet is free of obstacles.

12.3 Anti-reflective glass

Anti-reflective glass for the gas fireplaces consists of polished ceramic glass on which metal oxide coating layers have been applied. The thickness of the coating is checked down to the nanometer to perfectly control the reflection level. The reflectance level of untreated glass is on average 8%, while an anti-reflective glass provides a reflection of only 0.7%. Thanks to the new coating technology, anti-reflective glass is completely invisible when approached straight ahead. This gives the gas fireplace a super realistic fireplace effect. In this way you use all the advantages of a gas fire, while the atmosphere and warmth nevertheless match the fireplace.

Maintenance of anti-reflective glass for anti-reflective windows is of great importance to observe certain maintenance instructions. In order not to damage the coating layers, the use

of hard (sanding) sponges, abrasives and cleaning agents with ammonia is prohibited. Only use a neutral cleaning product (neither acidic nor alkaline), such as Element4 window cleaner (Item No. 4500926). The cleaning agents that you normally use should therefore not be used with an anti-reflective glass. Use a soft cloth or sponge (not paper).

Just as with ordinary ceramic glass, the white haze that results from the first combustion must be removed with anti-reflective glass. After that, sporadic maintenance is sufficient.

Please note, that glass may stain more often with an open fire, due to the fresh air coming from the installation room. The fresh air may contain more pollution or particles, which when burned in the fireplace may settle on the glass and soot.

When cleaning always rub the window completely dry: Residual water can stain the coating. Fingerprints are more visible on anti-reflective glass, therefore wear (rubber) gloves when grasping the window. If the window is lifted with a suction cup, the rubber of the suction cup must be dry to avoid damage to the coating.

12.4 Ceramic parts

This appliance is equipped with a ceramic fire bed with heat-resistant ceramic fibers, or artificial glassy silicate fibers. Excessive exposure to this material may cause irritation to the eyes, skin and respiratory tract. We therefore recommend that the dust emission is reduced as much as possible when handling these materials

12.5 Replacement of parts

If parts need to be replaced, use only original parts from the manufacturer. The warranty will be void if non-standard parts are used. In addition, they can be dangerous.

12.6 Packaging materials

The packaging of the device is recyclable.

The following packaging materials may have been used:

- Cardboard
- CFC-free foam (soft)
- Wood
- Plastic
- Paper

These materials must be disposed of in a responsible manner and in accordance with government regulations.

Batteries are regarded as chemical waste. The batteries must be disposed of in a responsible manner and in accordance with government regulations. Remove the batteries first before discarding the remote control.

The government can also provide information about the responsible disposal of discarded appliances.

13 COMMISSIONING THE APPLIANCE

13.1 Pilot Ignition Check

1. Ignite the pilot light as described in the User Instructions
2. Check that the pilot flame stays alight
3. Extinguish the pilot light

13.2 Main Burner Check

1. Ignite the pilot light as described in the User Instructions
2. Turn on the main burner as described in the User Instructions
3. Check that the pilot smoothly cross-lights to the main burner and that the main burner and pilot stay alight
4. Extinguish the appliance fully

13.3 Pressure Check

The appliance is preset to give the correct heat inputs as listed in the technical details. No further adjustment is necessary. Always check the inlet pressure and burner pressure.

1. Turn off the gas valve on the appliance
2. Release the screw on the Inlet Pressure test point on the gas valve and connect a pressure gauge Manometer
3. Check that the measured pressure is as the prescribed supply pressure
4. Perform the test when the appliance is burning on full and with only the pilot alight
5. If the pressure is low, check the gas supply pipes are to a correct sizing
6. If the pressure is too high (more than 5 mbar over) the appliance may be installed, but the gas supply company should be contacted
7. Release the screw on the Burner Pressure test point on the gas valve and connect a manometer
8. Check that the measured pressure is as detailed in the technical details
9. The measured value should be within +/- 10% of the described value. If this is not the case, please contact the supplier.

Note: After checking the pressures and removing the manometers, the screws in the Pressure Test points must be closed, and the system must be checked for gas-tightness.

14 SERVICING

Turn the appliance OFF and isolate the gas supply. Ensure the appliance is fully cold before attempting to start servicing the appliance. No liability can be accepted by Element4 for injury caused by burning or scolding by a hot appliance.

A suggested procedure for servicing is listed below.

1. Remove windows according the steps in **Chapter 10**.
2. Carefully remove the ceramic components (including Embers) or grvels
3. Use a vacuum cleaner to clean the top of the burners and grate
4. Remove grate
5. Using a vacuum cleaner, fully clean around the Burner
6. The pilot assembly is clearly visible. Use the vacuum cleaner and a soft brush to clean the pilot assembly Never modify or bend the Thermocouple
7. Turn on the gas supply and check for leaks, check the burners and pilot for good condition and operation
8. Replace grate
9. Replace the firebed arrangements
10. Replace window assembly and trims
11. Check the flue system and terminal, making sure that the terminal vent is fully clear
12. Light the appliance and test setting pressures
13. Check the safe operation of the appliance

14.1 Cleaning the Ceramics

Remove the ceramics as detailed in **CHAPTER 10**.

Gently clean the ceramics in the open air, using a soft brush and a vacuum cleaner. Where necessary replace damaged components only with genuine Element4 specified parts. Seal any scrap ceramics in plastic bags and dispose at proper refuse sites. When using a vacuum cleaner, it is recommended that one with a HEPA filtering system is used.

Re-fit the Firebed arrangement, re-seal the appliance and check the safe operation of the appliance.

14.2 Servicing the Burners

Remove the Burner Top Assemblies as detailed in to 1 to 3 above.

The pilot is now clearly visible. The pilot, including the Thermocouple, can be replaced/ serviced by removing / raising the pilot assembly from its mounting. This is done by removing the two screws on the surface of the pilot. The fittings on the under-side of the pilot can be un-done using a 10mm spanner where appropriate.

To access the Main Burner Injectors, the Burner base units must be removed. This is done by removing the four bolts (M5, 8mm socket tool) holding the burner in. With these four bolts removed, the Burner base can be raised up through the Firebox, and the Injectors can be easily accessed.

When replacing any parts use only original specified parts.

A FIRST AID FOR MALFUNCTION

Below you will find an overview of the possible cause and solution in the event of a failure.

Problem	Possible Cause	Solution
A No transmission (motor will not run)	1 Batteries in the receiver empty	Replace the batteries (4x 1.5V AA)
	2 Batteries hand remote empty	Replace the batteries (2x 1.5V AAA)
	3 6V-adapter defective	Check the adapter Replace the adapter if necessary
	4 Hand transmitter not linked to the receiver	Connect the hand transmitter to the receiver Press and hold the reset button (see Figure A.1) until you hear two beeps. After the second longer tone, release the reset button. Press within 20 sec. on the down arrow on the hand transmitter Two short beeps confirm that the code has been set. Tip: For this action a video is available on our youtube channel
B Receiver does not receive a signal	1 Receiver defective	Replace receiver
	2 Bend pin connection on the receiver	Bend the pen straight again (See Figure A.2)
	3 Hand transmitter defective	Replace the hand transmitter (see Figure A.3)
	4 No or bad reception. The receiver is in a metal box! This disturbs the reception.	Change the position of the antenna (See Figure A.4)
C No ignition; no beep	1 Receiver defective	Reset the receiver (See K1) If necessary, replace the receiver
D No ignition; receiver gives a five-second beep	1 Loose contact in the thermocouple circuit / wiring 2nd thermocouple	Check plug connections Repair the wiring if necessary
	2 Receiver defective	Replace receiver
	3 Magnetic coil defective	Replace gas block / or only coil coil
	4 Bent pin connection on the receiver	See B2
	5 Thermocouple broken	Check the thermocouple at the bottom of the pilot burner if necessary. fracture. Replace the thermocouple if necessary
E Ignition stops after 1 spark	1 Mass on the gas block not OK	<ul style="list-style-type: none"> Remove the 20mm Torx screw (See Figure A.5) File or scrape the surface thoroughly Reinstall the Screw and tighten it securely Tip: For this action a video is available on our youtube channel
F No pilot flame but there is an ignition	1 No gas	Check / measure gas inlet pressure
	2 Air in the gas line	Venting the gas line can be done via test point A (Figure A.6) Tip: For this action a video is available on our youtube channel
	3 Pilot flame blocked	Check pilot burner (Figure A.7)
	4 Thermocouple wiring is incorrect	Check the wiring on the interrupter (See Fig. A.8) Check the wiring on the receiver (See Fig. A.9)



Figure A.1: RESET-button

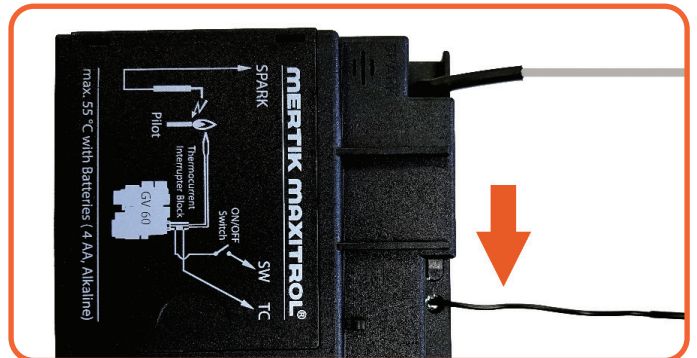

Figure A.4: Antenna



Figure A.2: Bend pin

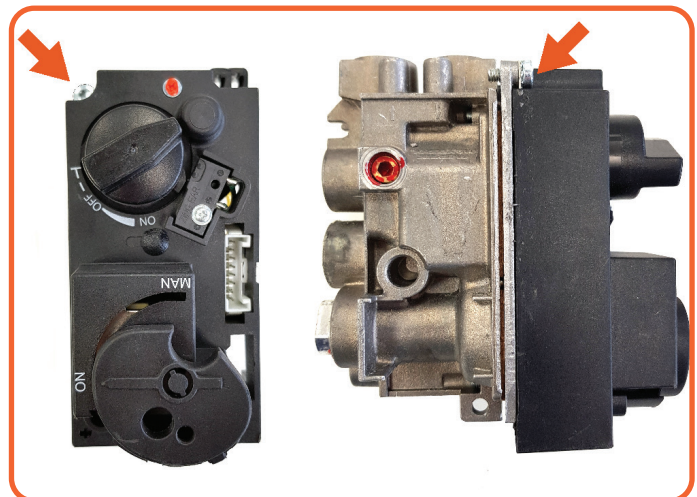

Figure A.5: Torx screw

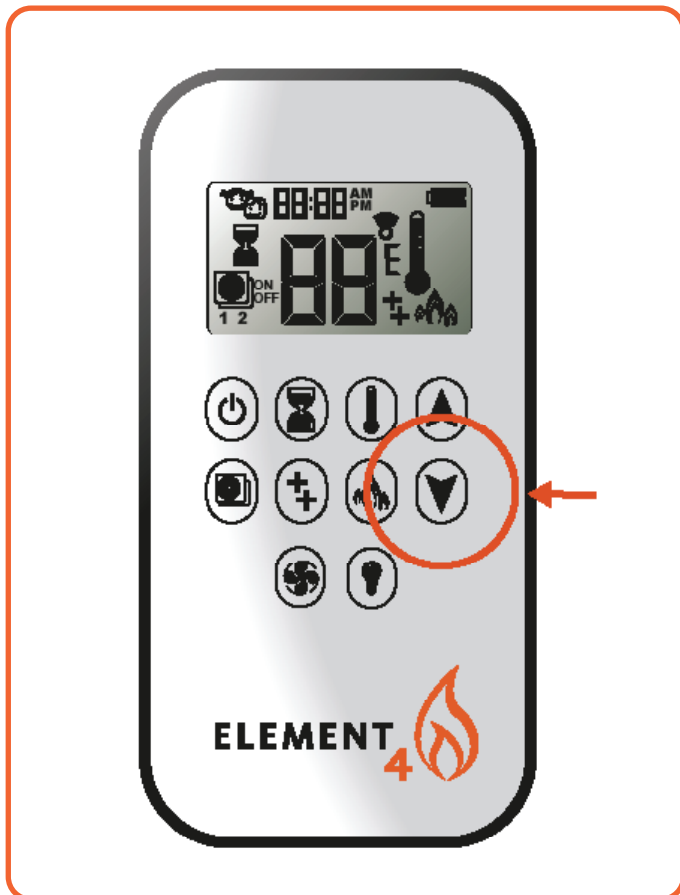

Figure A.3: "Double plus"-button on the remote

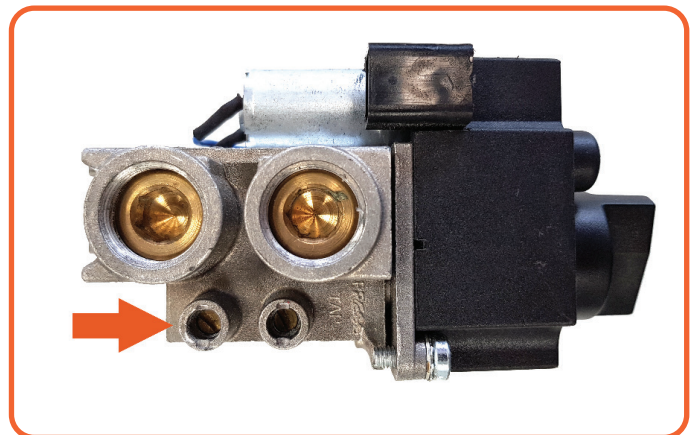

Figure A.6: Testpoint A

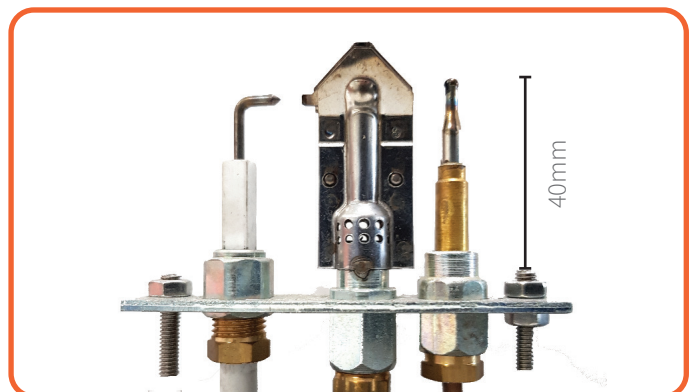

Figure A.7: Pilot set

APPENDICES

Problem	Possible Cause	Solution
G The pilot light goes on but goes out immediately when the main burner switches on	1 Insufficient voltage across the thermocouple or too much resistance in the thermocouple circuit	Place the measuring pins of the multimeter on the ground and black cable of the breaker. This value must be at least 4.5 mV. See again Figure A.8 . Tip: For this action a video is available on our youtube channel
	2 Gas pressure loss may cause the pilot flame to be too small	Check and measure the pre-pressure via test point A (See Figure A.6) Tip 1: Measure the pre-pressure load and unloaded Tip 2: For this action a video is available on our youtube channel
	3 Thermocouple defect	Replace thermocouple Tip: Always use a new pressure piece when a thermocouple is replaced
H Receiver gives 3 short beeps after each command:	1 Batteries in the receiver are empty	Replace the batteries 4x 1.5V AA
I Pilot is on but the main burner does not start working:	1 Gas valve is on manual	Set Knob A must be in the ON position (See Figure A.10)
J No response from the receiver when the fireplace is started via smartphone or tablet.		Disconnect the Wi-Fi box from the receiver Click the plug from the SI connection on the receiver (See Figure A.11) Tip: Reset the home router If the fireplace now functions normally, check the Wi-Fi settings
K Hearth does not respond via Domotica system		Disconnect the cabling on the Domotica system and start the fire with the hand transmitter When the fireplace now reacts normally, the problem is in the Domotics. See Figure A.12 for a scheme of the domotica system

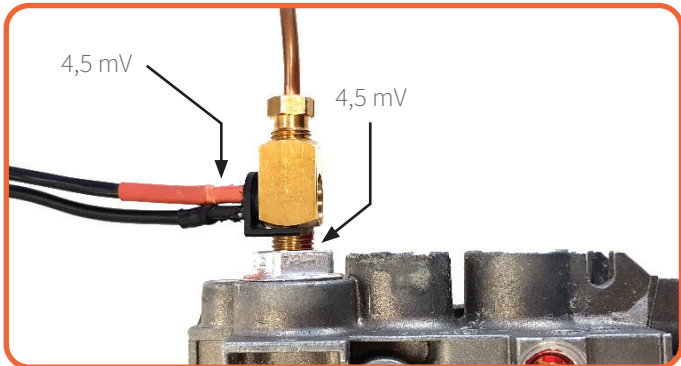

Figure A.8: interrupter



Figure A.11: SI-port

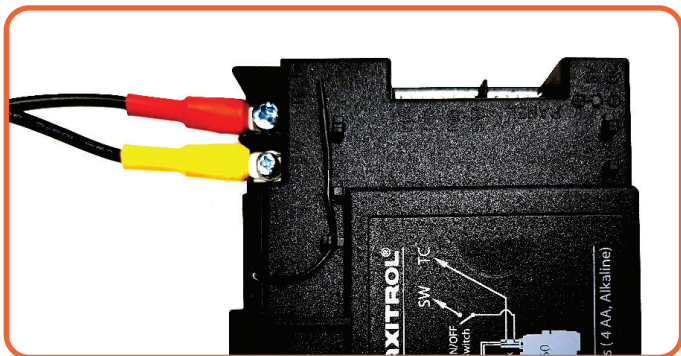

Figure A.9: Wiring receiver

MODE	CONTACT
Ignition Main Burner	1 & 3
High Flames	1
Pilot	3
Extinguish Main Burner	1, 2 & 3
Ignite second burner	1 & 2
Extinguish second burner	2 & 3

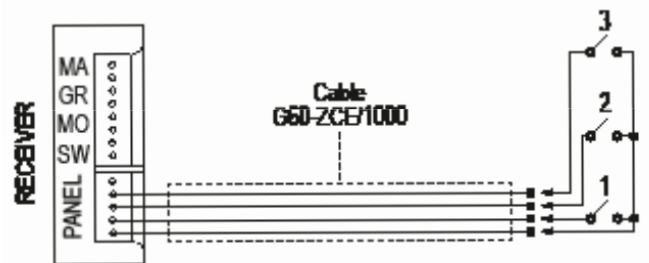

Figure A.12: Domotica system

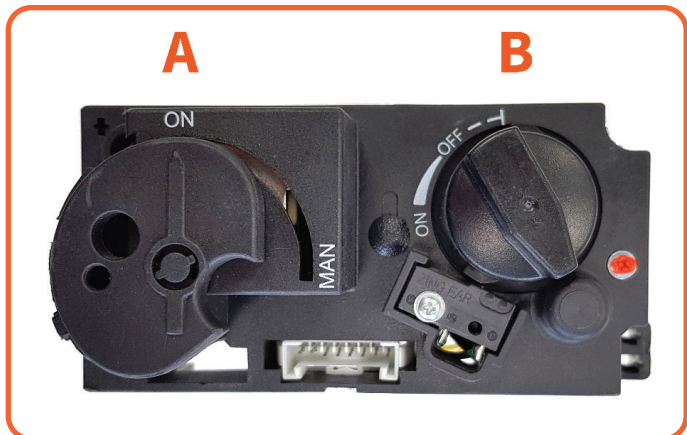

Figure A.10: Button A on "On"

B ERRORS CODES PROCONTROL APP

B.1 Messages shown in app

Error code	Message in App	Description	Possible cause
F02	Contact Service.	<ul style="list-style-type: none"> 5 sec. beep from Receiver Fire is not responding; no ignition 	<ul style="list-style-type: none"> Microswitch not making contact with cam on motor knob Motor wiring is incorrect Reversed polarity or faulty Microswitch Bent Motor Knob
F03	Contact Service.	<ul style="list-style-type: none"> 5 sec. beep from Receiver Ignition process is interrupted Fire is not responding; no ignition 	<ul style="list-style-type: none"> Thermocouple wiring is incorrect Thermocouple wiring is not connected ON / OFF switch in O (OFF) position
F04	Ignition Sequence Malfunction. Wait 1 minute. Retry ignition.	<ul style="list-style-type: none"> No pilot flame within 30 sec. NOTE: After 3 failed ignition sequences F06 shown 	<ul style="list-style-type: none"> No gas supply Air in pilot supply line No spark Reversed polarity in thermocouple wiring Check for correct pilot orifice (LPG to NG or vice versa)
F05	Contact Service.	<ul style="list-style-type: none"> Pilot burner fails to ignite or shuts off Motor stays in pilot position 	<ul style="list-style-type: none"> Not enough thermo-voltage Air in the pilot supply line Low inlet pressure Bad thermocouple
F06	Contact Service.	<ul style="list-style-type: none"> 3 failed ignition sequences within 5 minutes Fire is not responding; no pilot flame 	<ul style="list-style-type: none"> No gas supply Air in pilot supply line No spark Reversed polarity in thermocouple wiring Check for correct pilot orifice (LPG to NG or vice versa)
F07	Replace Handset Batteries.	<ul style="list-style-type: none"> Battery icon flashes on handset display 	<ul style="list-style-type: none"> Low battery power in handset
F08	Contact Service.	<ul style="list-style-type: none"> Low Receiver battery power supply Short beeps for 3 sec. during motor turn 	<ul style="list-style-type: none"> Low Receiver battery power supply
F10	Contact Service.	<ul style="list-style-type: none"> Pilot lit Main burner fails to ignite and pilot shuts off Ignition is blocked for 2 minutes 	<ul style="list-style-type: none"> 2nd thermocouple is out of position 2nd thermocouple wiring is incorrect Gas logs out of position Gas ports for burner are blocked
F12	Contact Service.	<ul style="list-style-type: none"> Motor turns to pilot position 	<ul style="list-style-type: none"> Receiver powered by batteries and Receiver temperature exceeds 60 °C Check air circulation and heat shield
F13	Contact Service.	<ul style="list-style-type: none"> Motor turns to pilot position Fan at level 4 for 10 minutes (T > 80 °C) 	<ul style="list-style-type: none"> Receiver temperature exceeds 80°C Check air circulation and heat shield
F14	Contact Service.	<ul style="list-style-type: none"> 5 sec. beep from Receiver Fire is not responding; no ignition 	<ul style="list-style-type: none"> Receiver software doesn't support a 2nd thermocouple Wrong Receiver
F15	Contact Service.	<ul style="list-style-type: none"> 5 sec. beep from Receiver Fire is not responding; no ignition 	<ul style="list-style-type: none"> 2nd thermocouple wiring is incorrect 2nd thermocouple wiring is not connected
F16	Handset out of range.	<ul style="list-style-type: none"> No temperature shown in App 	<ul style="list-style-type: none"> Handset out of range for more than 1.5 h Electrical interference
F17	Contact Service.	<ul style="list-style-type: none"> Fire is not responding; no ignition 	<ul style="list-style-type: none"> Inlet voltage exceeds 7.25 V Malfunction of Mains Adapter
F18	Contact Service.	<ul style="list-style-type: none"> Switch panel / touch pad not functioning 	<ul style="list-style-type: none"> Switch panel / touch pad is locked Short in cable or button
F19	Contact Service.	<ul style="list-style-type: none"> Pilot drops when Motor opens main gas 	<ul style="list-style-type: none"> Insufficient thermo-voltage Thermocouple malfunction Low inlet gas pressure Improper thermocouple flame impingement Carbon build-up on thermocouple Valve malfunction Resistance in thermocurrent circuit
F26	Contact Service.	<ul style="list-style-type: none"> It is not possible to increase flame height after ignition Fan at level 4 for 10 minutes (T > 80 °C) 	<ul style="list-style-type: none"> Receiver powered by batteries and Receiver temperature exceeds 60°C Receiver powered by mains power and Receiver temperature exceeds 80°C
F27	Contact Service.	<ul style="list-style-type: none"> Fire is not responding No electronic control of fire 	<ul style="list-style-type: none"> No handset or Wi-Fi Box connected to Receiver for more than 3 hours
F28	On-Demand Pilot	<ul style="list-style-type: none"> Pilot shuts off after a predefined time 	<ul style="list-style-type: none"> Pilot shuts off after no motor movement for a predetermined time

APPENDICES

Error code	Message in App	Description	Possible cause
F31	Contact Service.	<ul style="list-style-type: none"> Fire is not responding No electronic control of fire 	<ul style="list-style-type: none"> Receiver or Wi-Fi Box malfunction Connection cable from Receiver to Wi-Fi Box defective
F41	Check Wi-Fi	<ul style="list-style-type: none"> Fire is not responding No electronic control of fire 	<ul style="list-style-type: none"> No Wi-Fi connection to myfire Wi-Fi Box, router and / or smart device Wi-Fi in smart device is deactivated
F42	Check Wi-Fi	<ul style="list-style-type: none"> Fire is not responding No electronic control of fire 	<ul style="list-style-type: none"> No power to router No Wi-Fi connection to router and / or smart device Smart device not in the correct home network
F43	No Receiver Connected. Contact Service.	<ul style="list-style-type: none"> Fire is not responding No electronic control of fire 	<ul style="list-style-type: none"> No communication between Receiver and myfire Wi-Fi Box
F44	Contact Service.	<ul style="list-style-type: none"> No temperature shown in App N.a. (not applicable) displayed in App 	<ul style="list-style-type: none"> Handset not within range Low battery power in handset
F49	Contact Service.	<ul style="list-style-type: none"> No electronic control of fire 	<ul style="list-style-type: none"> Receiver software < 8.32 is not supported by myfire Wi-Fi Box Version 2
F50	Contact Service.	<ul style="list-style-type: none"> No electronic control of fire 	<ul style="list-style-type: none"> Handset software < SW 231 is not supported by the myfire Wi-Fi Box Version 2

B.2 Messages shown in remote

Error code	App Message	Time	Description	Possible Cause
F04	F04	4 sec.	<ul style="list-style-type: none"> No pilot flame within 30 sec. NOTE: After 3 failed ignition sequences F06 shown 	<ul style="list-style-type: none"> No gas supply Air in pilot supply line No spark Reversed polarity in thermocouple wiring
F06	F06	4 sec.	<ul style="list-style-type: none"> 3 failed ignition sequences within 5 minutes Fire is not responding; no pilot flame 	<ul style="list-style-type: none"> No gas supply Air in pilot supply line No spark Reversed polarity in thermocouple wiring Check for correct pilot orifice (LPG to NG or vice versa)
F07	F07	Until batteries replaced	<ul style="list-style-type: none"> Battery icon flashes on handset display 	<ul style="list-style-type: none"> Low battery power in handset
F09	F09	4 sec.	<ul style="list-style-type: none"> Fire is not responding No electronic control of fire 	<ul style="list-style-type: none"> Down arrow button was not pressed during pairing Receiver and handset are not synced
F46	F46	4 sec.	<ul style="list-style-type: none"> Fire is not responding Intermittent response No electronic control of fire 	<ul style="list-style-type: none"> No or bad connection between receiver and handset No power at Receiver (batteries low) Mains adapter faulty, set not communicating with Receiver)

C FAULTS AND ERROR CODES IN THE REMOTE

This appendix can be consulted when error messages occur in the application for smartphone and tablet.

C.1 F41 error

This message will appear if there is no or bad Wi-Fi reception, this can be between app and router or Wi-Fi box and router

By closing the App and opening it again, this is solved in most cases.

Cause

The cause may be that the ProControl module is blocked or is too far away from the router. See: **router information**.

Possible solution

- Only place an external router for the ProControl module
- Strengthen existing Wi-Fi signal
- Resetting the router.

C.2 Router information

C.2.1 Minimum requirement

- Compatible with IEEE 802.11n / g / b
- WPA2 encryption
- Radio frequency 2.4 GHz band
- Wireless automatic channel: Automated search for WLAN radio channel that is free from interference.
- Support for the User Datagram Protocol (UDP)

C.2.2 Wi-Fi Router

It is important to think carefully about the location of a router. This device spreads the wifi signal in and around your home. Therefore, preferably choose a central position. You prevent long distances from occurring. Many people put the router in the meter cupboard, because that is where the internet comes in at many households. A bad choice! For a powerful WiFi signal, the router needs as much space as possible. Therefore, do not place the device near a wall or on the ground. Some routers have multiple antennas that you can target. Try to spread these antennas so that you increase the range.

C.2.3 Jammers

Many devices also emit radio waves just like your router. These include microwave ovens, wireless doorbells, baby monitors, Bluetooth adapters, wireless music systems, DECT telephones and security cameras. These devices can disrupt your wireless network (interference), so the Wi-Fi connection is not optimal. Try to keep jammers as far away as possible from the router. Neighboring wireless networks also play a role in the Wi-Fi area.

C.2.4 Frequency

By default, most routers use the 2.4 GHz band to broadcast the Wi-Fi signal. The disadvantage is that this frequency band is very busy, so that there is quickly interference. There are a lot of competing users and jammers using the same radio waves. Since most “older” laptops, smartphones, tablets and other devices can not connect via the 5GHz band, the ProControl module is not suitable for 5GHz band.

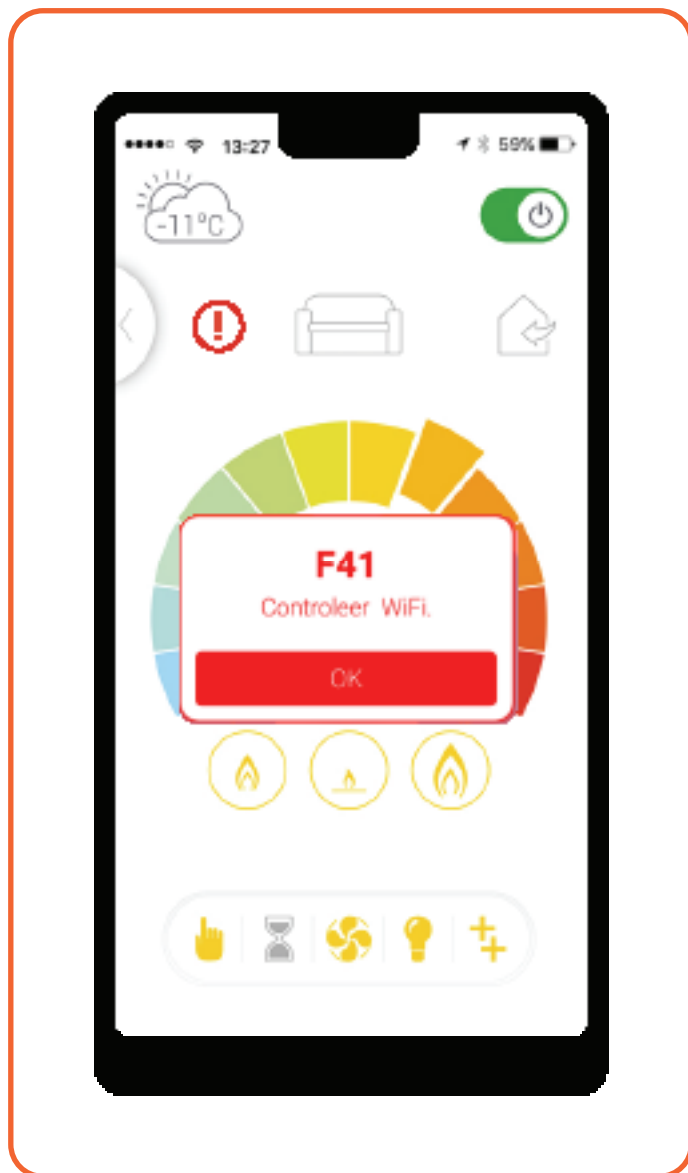

Figure C.1 - Error F41 screen of the ProControl App

D LOCATION TERMINAL

D.1 Terminal location with vertical exhaust (B11)

Distance	Exhaust 1,2 of 3	
At the same roof level	> 6m	*
At a different roof level	> 3m	* & **
On a lower wall	> 2m	*
On a higher sloping surface	> 6m	***

“Distance” = minimum distance required to position the exhaust in order to prevent adverse effects in relation to;

1. A ventilation opening of a used room, toilet or bathroom
2. Supply of heated air when the supply flows through a used room.
3. A window that can be opened and located in the vicinity of a used room, toilet or bathroom.

* If the required distance is not feasible, the rules regarding the exit position have priority.

** If the exhaust is placed at least one meter higher than the inlet opening, or a window that can be opened.

*** If the required distance is not feasible, the exhaust must be placed at least one meter above the highest façade / roof.

(4) The terminal may not be placed closer than 300 mm to an opening in the building such as a window frame.

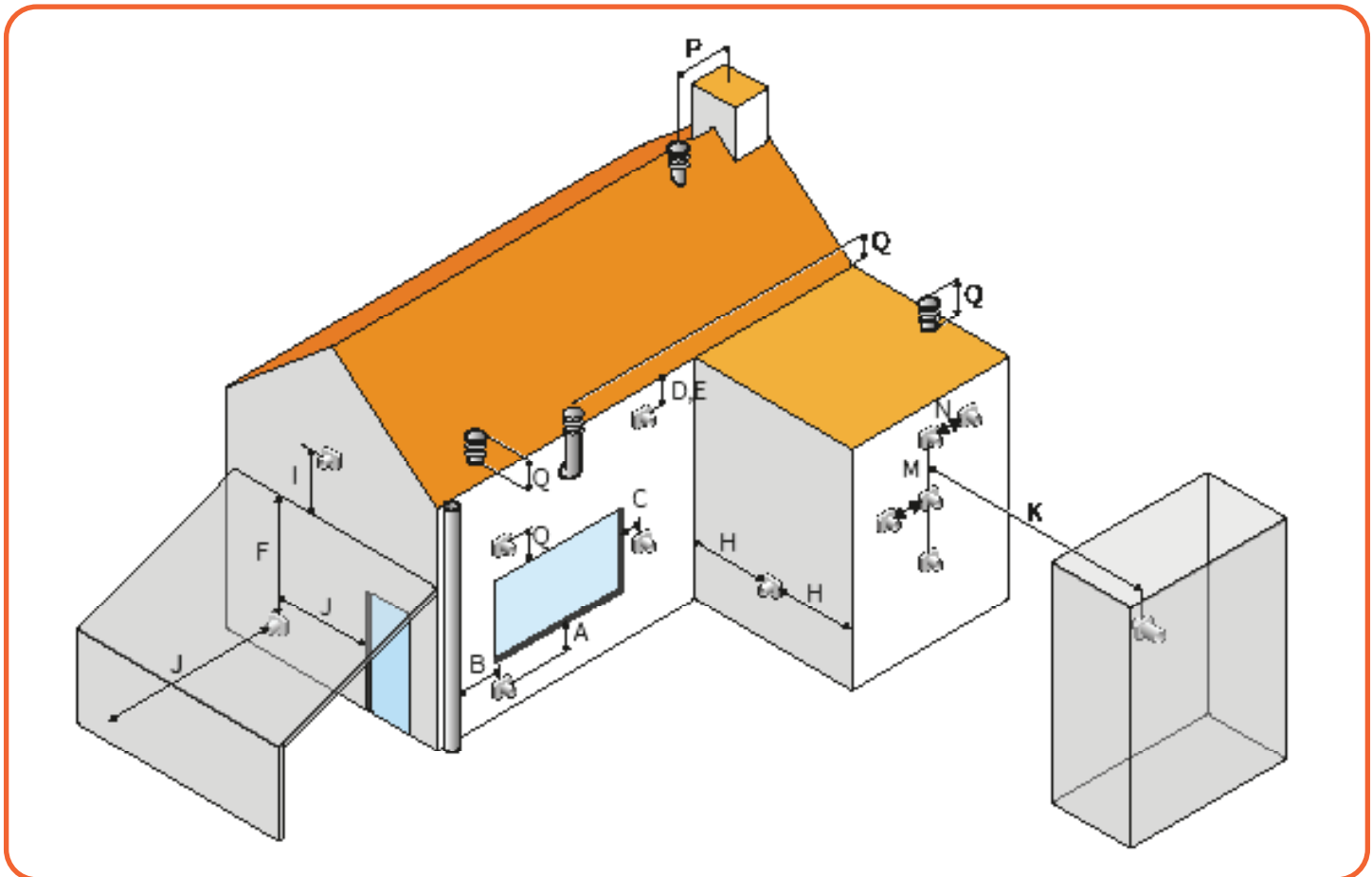

Figure D.1 - Terminal Location

E TECHNICAL DATA

The dataplate specifies for which type of gas, gas pressure and for which country this appliance is intended. The nameplate is attached to a chain. It must remain attached to the chain.

Note: Check whether the appliance is suitable for the gas type and gas pressure on site.

		Gas type ▶		NATURAL GAS					LPG			
		Country of use ▶		I _{2H}	I _{2E}	I _{2E+}	I _{2ELL}	I _{2L} / I _{2EK}	I _{3B/P}	I _{3B/P}	I ₃₊	I ₃₊
Gas Category ▶		Unit	G20	G20	G20/G25	G20/G25	G25/G25,3	G30/G31				
Supply pressure	mbar	20	20	20 / 25	20	25	30	50	28 - 30/37		30	
Burner pressure	mbar	8	18	18/23	23	18	28	28	36		29	
Gross input	kW	6,9	6,9	6,9 / 6,5	6,5	6,2	6,9	6,7	6,7		6,0	
Net input	kW	6,2	6,2	6,2 / 5,6	6,2	5,6	6,3	6,2	6,2		5,4	
max. Heat output	kW	5,3	5,3	5,3 / 5,6	5,3	4,8	5,3	5,3	5,3		4,6	
min. Heat output	kW	1,8	1,8	1,8 / 1,9	1,8	1,6	1,8	1,8	1,8		1,5	
(Max.) Gas usage	m ³ /uur	0,5	0,65	0,65 / 0,71	0,66	0,65 / 0,71	0,2	0,2	0,24		0,21	
NOx	mg/kWh _{input}	<100					<100					
Pilot		SIT ODS OP9043					SIT ODS OP9288					
Burner injection		2 x 140 (Angle), 1 x 140 (Straight)					2 x 100 (Angle) , 1 x 100 (Straight)					

Type of flue

B11

Type of heat release / control room temperature (Select one)

With electronic control of the room temperature plus week switch

Additional electricity use

At rated heat output

el_{max} 9⁻⁵ kW

With minimal heat emission

el_{min} 9⁻⁵ kW

In standby mode

el_{sb} 9⁻⁵ kW

Other control options

Control of the room temperature with presence detection

Control the room temperature with open window detection

Power requirement for the permanent pilot light

Power requirement for the permanent pilot light (requirements applicable)

P_{pilot} Does not apply

With the option of remote control

With adaptive control of the start

With limitation of the operating time

Efficiency (NCV)

Efficiency at rated heat output

η_{th,nom} 80 %

Efficiency at min. heat output (indicative)

η_{th,min} 53 %

F ECODESIGN

Since 1 January 2018 every fireplace has been provided with an eco-label which is always supplied with the fireplace. The ecolabel shows which category the fireplace belongs to.

F.1 Ecolabels

The ecolabels for the different types of gas are indicated below, respectively G20, G25 and G30.

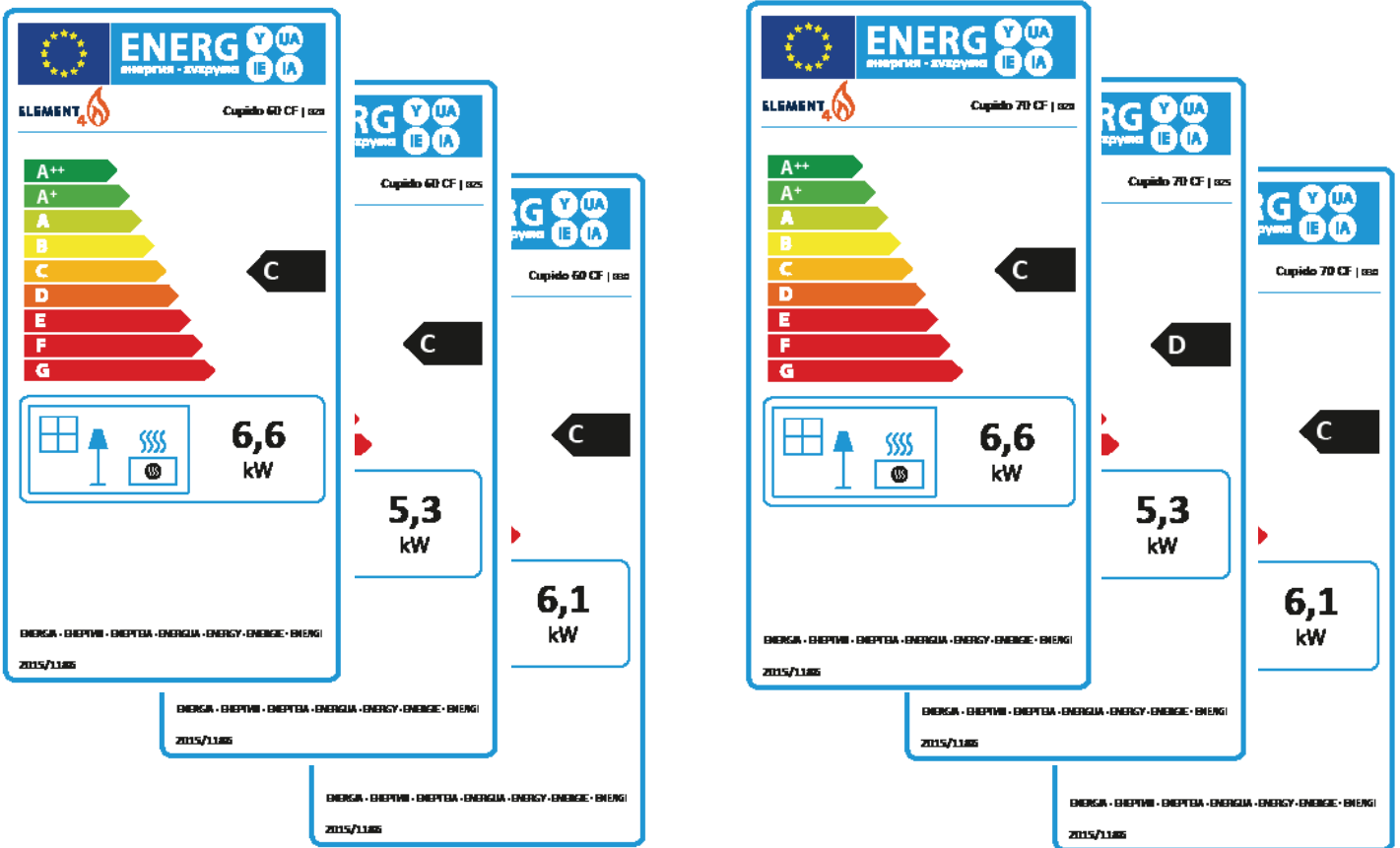

G DIMENSIONAL DRAWINGS

On the following ones you will find dimensional drawings of the conventional flue Cupido models with some of the important dimensions that you have to take into account when installing and installing your fireplace.

When you install the Cupido models in an existing chimney, there are two possible exhaust ports, respectively on top and on the back of the fireplace.

One of the both needs to be open, the other is than closed off. The top flue exhaust can be used to attached a flue pipe to. The back of the fireplace can be used when no flue is used, but the fireplace is only put inside the chimney.

NB: Opening up the back exhaust hole, stops debree from falling directly into the combustion chamber. To ensure a convection airflow around the fire, leave more room between the back of the fire and the wall.

APPENDICES

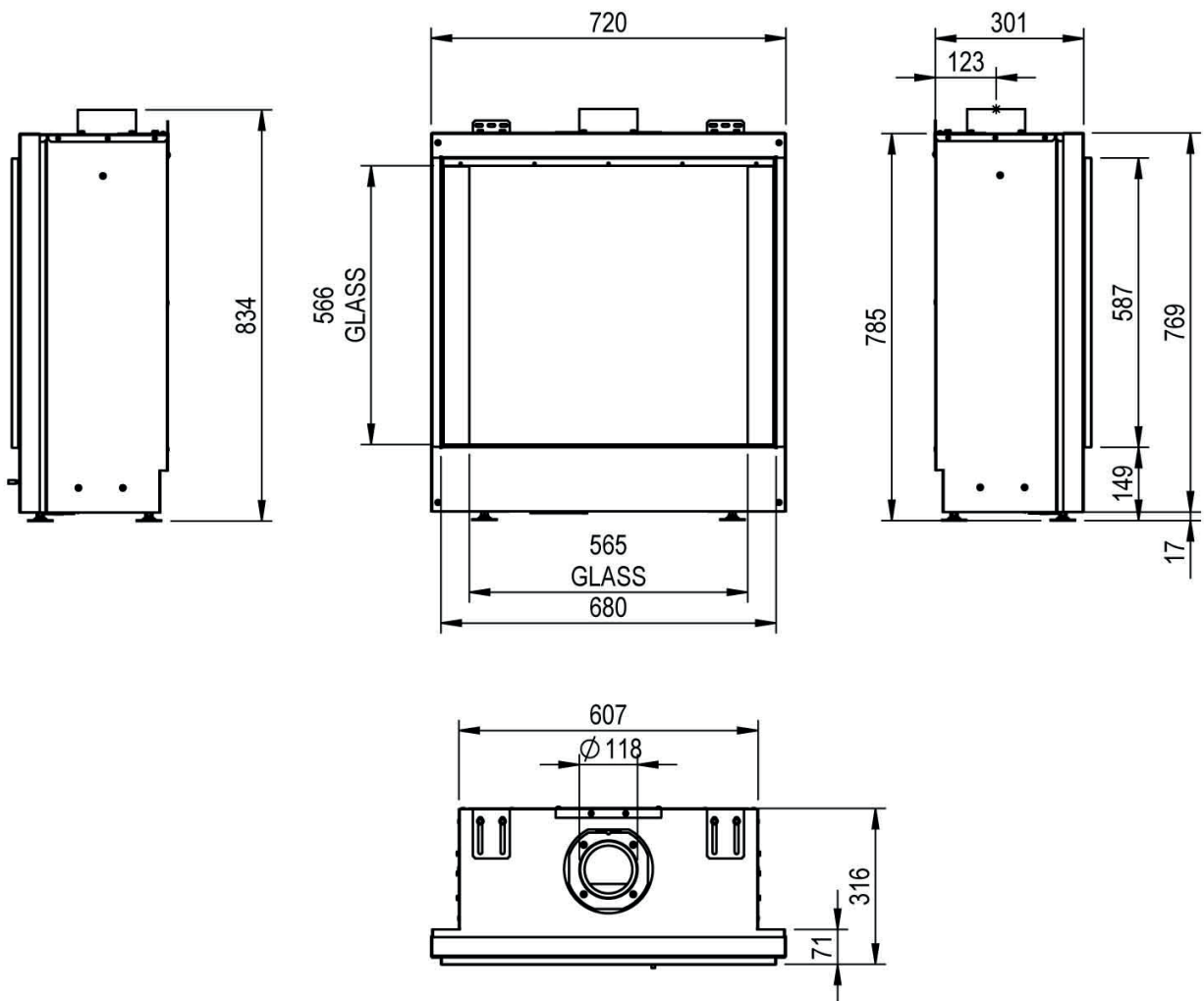
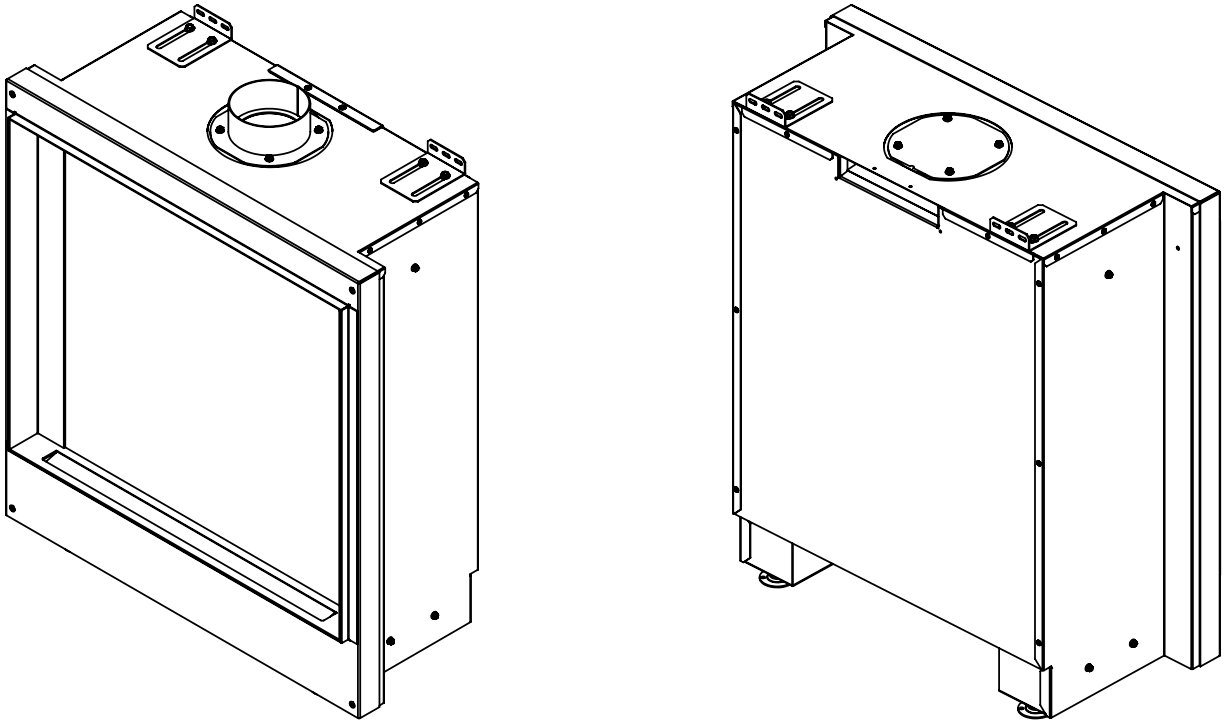

Figure I.1 - Technical drawing of Cupido 60 CF

APPENDICES

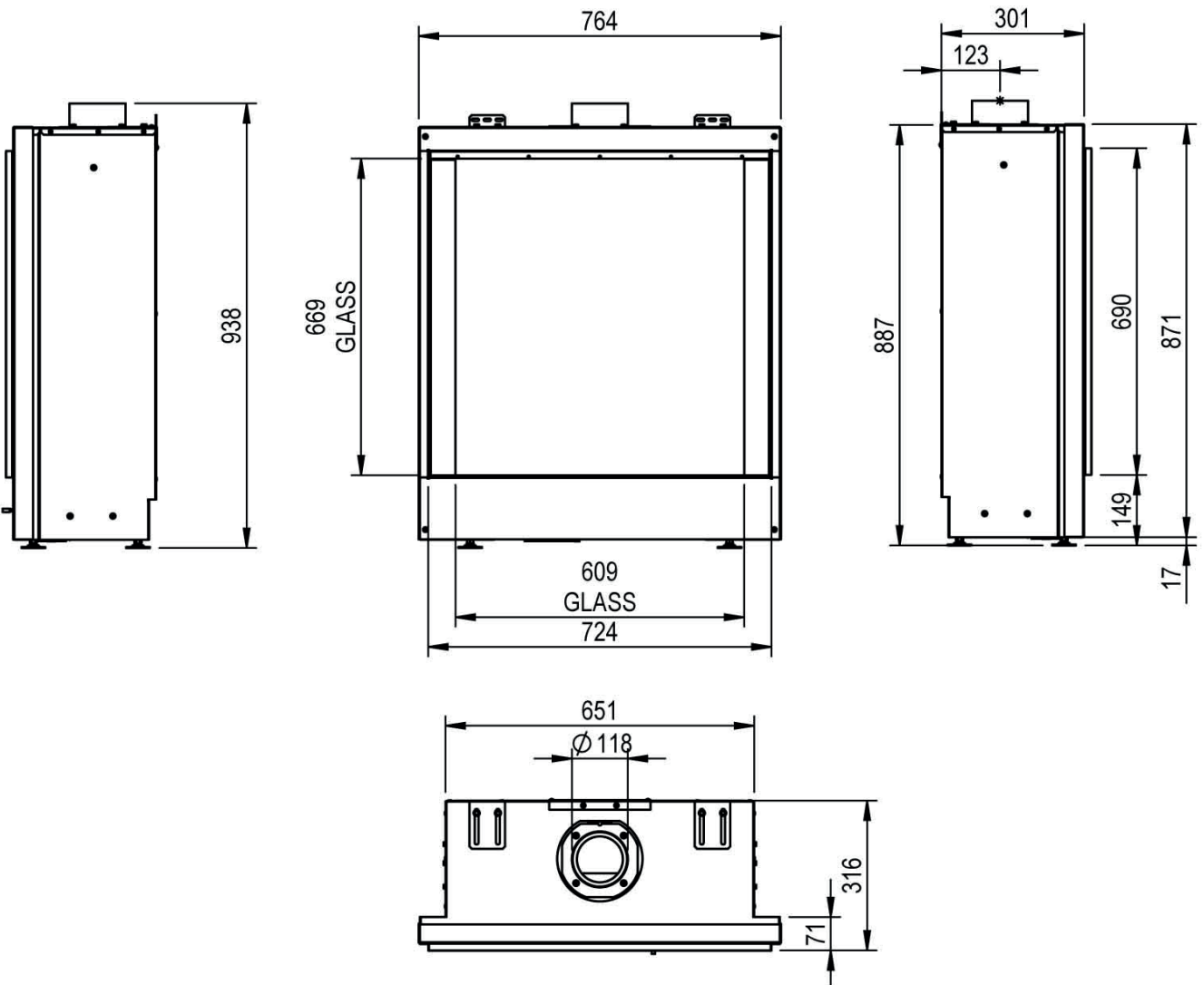
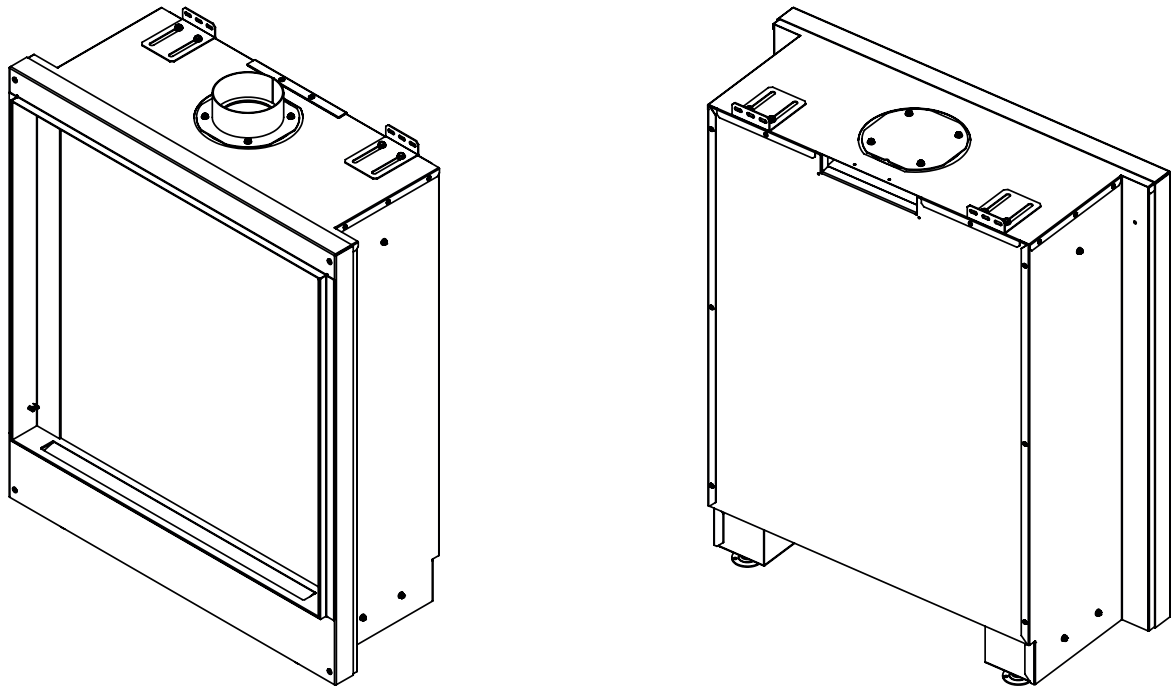

Figure I.2 - Technical drawing of Cupido 70 CF



ELEMENT 4 B.V.

Simon Stevinweg 6A
8013 NB Zwolle
The Netherlands
Info@element4.nl
www.element4fires.com

RELEASE DATE | 15/03/23